



MATTIAZZI
ITALY



MATTIAZZI
ITALY



MATTIAZZI



NOTES ON MATTIAZZI, THE COMPANY

In the 15 years since Mattiazzi developed its own brand, the company has become a reference point in furniture design. Founded in 1979, the business built a reputation for exceptional woodwork as a third-party producer in the heart of the 'chair triangle,' an esteemed manufacturing hub in northern Friuli Venezia Giulia, Italy.

In 2009, Nevio Mattiazzi (co-founder of the company with his brother Fabiano) and Cristina Salvati, the global sales and marketing director, opted for a significant strategic shift, establishing their own design label. Embracing a tradition ingrained in Italian craftsmanship, they worked with a select team of renowned designers to develop an exceptional collection of chairs, employing a production process that seamlessly combined digital technology with an artisanal approach.

The application of cutting-edge technology was not just utilitarian but an exploration of its potential. The introduction of computer-numerical-control (CNC) machinery, exemplified by the legendary eight-axis robot, has allowed Mattiazzi to produce products with industrial precision while evolving traditional methods and techniques.

Today, the company is notable for transitioning from a manufacturer to a well-regarded international design brand with an inventive approach to furniture design and production. Its modest size and efficient decision-making processes allow it to navigate the global market while remaining agile and nurturing experimentation. What sets it apart, however, is the conception of the company as a creative venture rather than merely a commercial endeavour.

Mattiazzi remains one of the few furniture brands committed to in-house production. The company ethos centres on the exclusive use of natural materials. From meticulously sourcing timber from

sustainably managed forests to using a chemical-free drying process, every step in the production process demonstrates a profound respect for the raw material, which is critical to more responsible, ethical design.

Among Mattiazzi's most iconic creations are the Branca chair (2010) by Sam Hecht and Kim Colins, which melds high-tech robotics with artisanal craftsmanship; the Osso chair (2011) by Ronan and Erwan Bouroullec, sculpted through CNC milling; the Medici (2013), Clerici (2015), and Cugino (2019) collections by Konstantin Grcic, which marry new typologies with the allure of natural wood, and Jasper Morrison's Zampa collection of quotidian chairs, armchairs and stools (2019).

Having strengthened its manufacturing capabilities, Mattiazzi developed a distinct brand identity free from the constraints of tradition. Instinctively, the company fostered collaborations with acclaimed art directors, recognising that the company's transformation could only be realised with the power of design.

Mattiazzi thrives on close collaboration with designers, and the company's ability to attract professionals interested in working in an environment that prioritises research and development is critical to its success. Recently, the design team welcomed Studio CE (Lisa Ertel and Anne-Sophie Oberkrome) and Marialaura Irvine, tasked with pioneering sustainable design solutions and radical approaches to raw and recycled materials.

Driven by a fervent pursuit of innovation, Mattiazzi's team remains steadfast in its commitment to resource efficiency and is united by a shared vision to confront the challenges of a changing world.

Francesca Picchi

MC THE MATTIAZZI COLLECTION

MC 26	PIPAIO Julie Richoz
MC 25	PAF PAF Marialaura Irvine
MC 24	SETA Foster + Partners
MC 23	OTO Studio CE
MC 22	FILO Ronan & Erwan Bouroullec
MC 21	LEVA Foster + Partners
MC 20	CUGINO Konstantin Grcic
MC 19	FRONDA Sam Hecht & Kim Colin
MC 18	ZAMPA Jasper Morrison
MC 16	FORCINA Leon Ransmeier
MC 15	QUINDICI Ronan & Erwan Bouroullec
MC 14	PRIMO Konstantin Grcic
MC 13	FACILE Lambl / Homburger
MC 12	TRONCO Sam Hecht & Kim Colin
MC 10	CLERICI Konstantin Grcic
MC 9	UNCINO Ronan & Erwan Bouroullec
MC 8	CHIARO Leon Ransmeier
MC 7	RADICE Sam Hecht & Kim Colin
MC 6	FIONDA Jasper Morrison
MC 5	SOLO Studio Nitzan Cohen
MC 4	MEDICI Konstantin Grcic
MC 3	OSSO Ronan & Erwan Bouroullec
MC 2	BRANCA Sam Hecht & Kim Colin
MC 1	HE SAID / SHE SAID Studio Nitzan Cohen



PIPAIO SIDE TABLE
cherry stain on beech

PIPAIO Julie Richoz



PIPAIO BOWL
dark red oiled on beech



PIPAIO SIDE TABLE
black oiled on beech



PIPAIO BOWL

· Beech frame

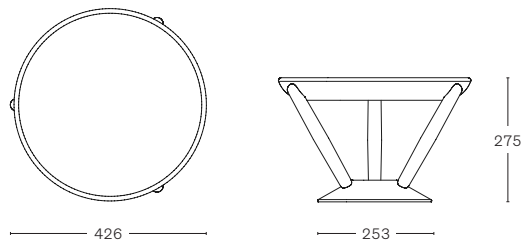

PIPAIO SIDE TABLE

· Beech frame

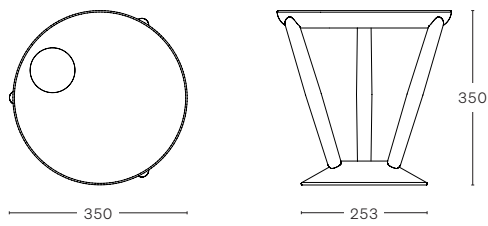

MATERIALS

FRAME

Beech



Cherry Black oiled Dark Red oiled
Stain oiled RAL 9004 RAL 3005



PAF PAF
natural wax on ash,
fabric upholstery

PAF PAF Marialaura Irvine

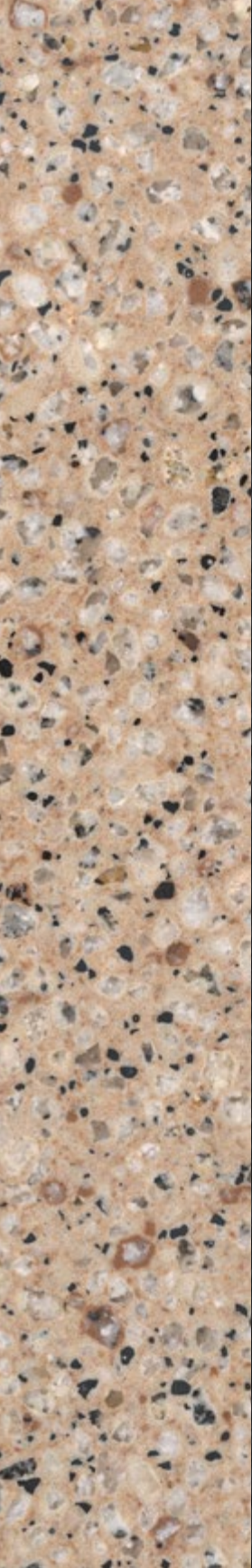

PAF PAF
natural wax on ash,
fabric upholstery



PAF PAF
walnut stain on ash,
fabric upholstery

PAF PAF CHAIR

- Ash frame with removable upholstery:
- Kvadrat Elle
- Rohi Arco
- Sørensen Prestige
- Torri Lana Rico

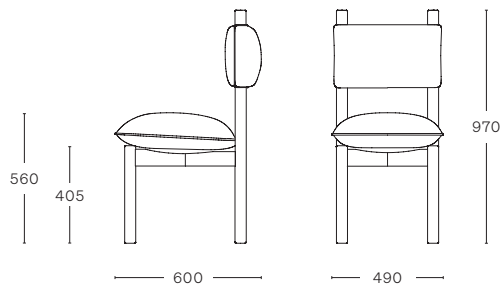

MATERIALS

FRAME Ash



Natural Walnut Stain

UPHOLSTERY Kvadrat Elle

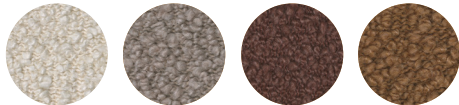

0200 0220 0350 0480

Rohi Arco

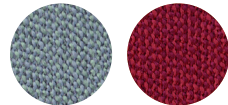

Aqua Cherry

Sørensen Prestige



Nougat 40677 Cognac 40680

Torri Lana Rico

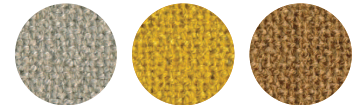

989.021 989.270 989.460



SETA
natural wax on ash

SETA Foster + Partners



SETA
natural wax on ash,
leather seat upholstery



SETA
grey aniline on ash

SETA
red aniline on ash

SETA CHAIR

- Ash frame
- Ash frame with non removable upholstery:
 - Kvadrat Basel
 - Kvadrat Steelcut Trio
 - Sørensen Envy
 - Sørensen Dunes®

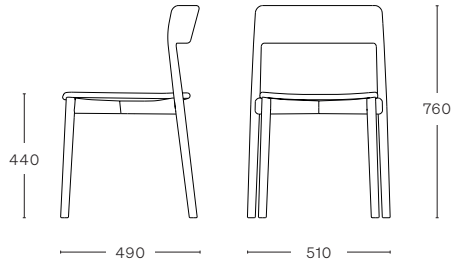











Stackable x8 

MATERIALS

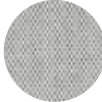
FRAME
Ash

UPHOLSTERY
Kvadrat Fabric

Sørensen Leather

											
Natural	Black RAL 9005	Grey NCS 4000	Red RAL 2002	Neon Blue RAL 5013	Basel 121	Basel 187	Steelcut Trio 3/105	Steelcut Trio 3/526	Steelcut Trio 3/796	Envy Black 20321	Dunes® Cognac 21000



OTO SIDE TABLE
natural wax on okoumé



OTO TWO-LEVEL CONSOLE
dark red aniline on okoumé



OTO BENCH
green beige aniline on okoumé

OTO MEDIUM CONSOLE
natural wax on okoumé





OTO MEDIUM CONSOLE
blue aniline on okoumé

OTO SIDE TABLE

· Okoumé frame

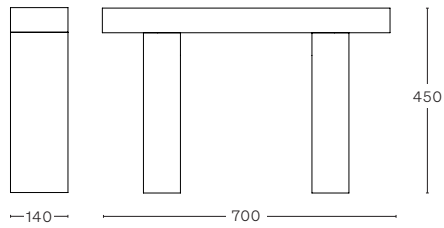

OTO MEDIUM CONSOLE

· Okoumé frame

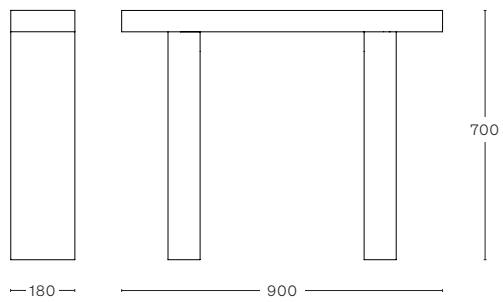

OTO TWO-LEVEL CONSOLE

· Okoumé frame

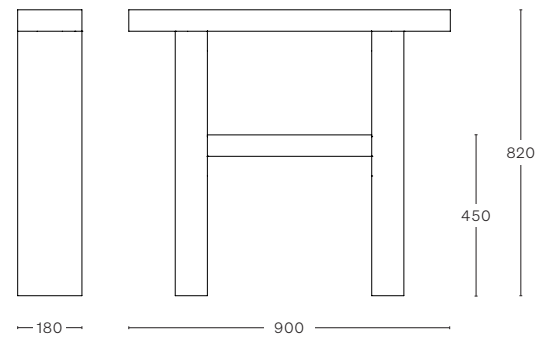

OTO BENCH

· Okoumé frame

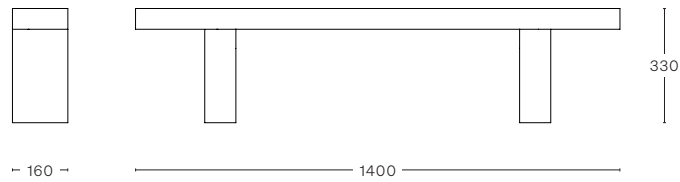

MATERIALS

FRAME

Okoumé

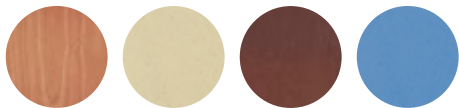

Natural
Green Beige RAL 1000
Dark Red RAL 3009
Blue NCS S 1550-R80B



FILO
black oiled on beech,
black rope

FILO Ronan & Erwan Bouroullec



FILO
yellow oiled on beech,
yellow rope





FILO
green oiled on beech,
green rope

FILO CHAIR

· Beech frame

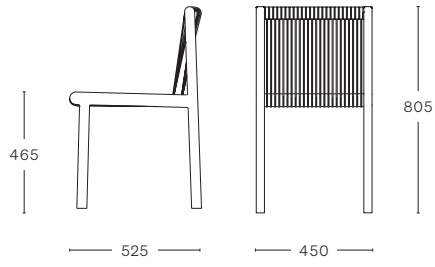

MATERIALS

FRAME

Beech



Black oiled
RAL 9004



Grey oiled
RAL 7015



Yellow oiled
RAL 1003



Green oiled
RAL 6008

SEAT AND BACK

Rope



Black



Grey



Yellow

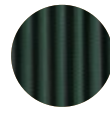

Green



REF. #0420
Photography: LICHT Gallery Showroom



REF. #0432
Photography: Christoph Mack

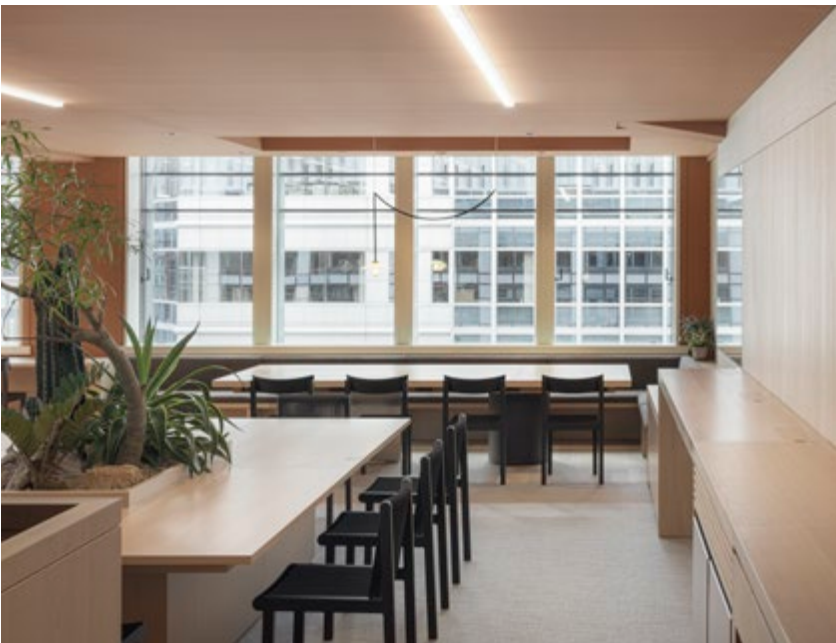

REF. #0339
Architecture: Flooat Inc. Photography: Tomooki Kengaku



LEVA
black aniline on ash

LEVA Foster + Partners



LEVA
natural wax on ash,
leather seat upholstery

LEVA ARMCHAIR

- Ash frame
- Ash frame with non removable upholstery:
 - Kvadrat Basel
 - Kvadrat Steelcut Trio
 - Sørensens Pure Nature
 - Sørensens Envy

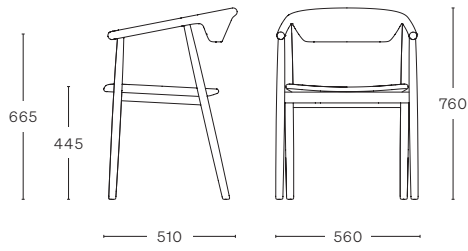

MATERIALS

FRAME

Ash



Natural



Black
RAL 9005



Red
RAL 2002



Grey
NCS 4000

UPHOLSTERY

Kvadrat Fabric

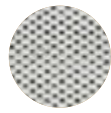

Basel
121

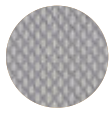

Steelcut Trio
3/105

Sørensens Leather



Pure nature
20805



Envy Black
20321



REF. #0418

Architecture: Case-Real Photography: Daisuke Shima



REF. #0307

Architecture: Borland Architecture Photography: Jack Level



CUGINO
black aniline on oak

CUGINO
natural wax on oak

CUGINO Konstantin Grcic



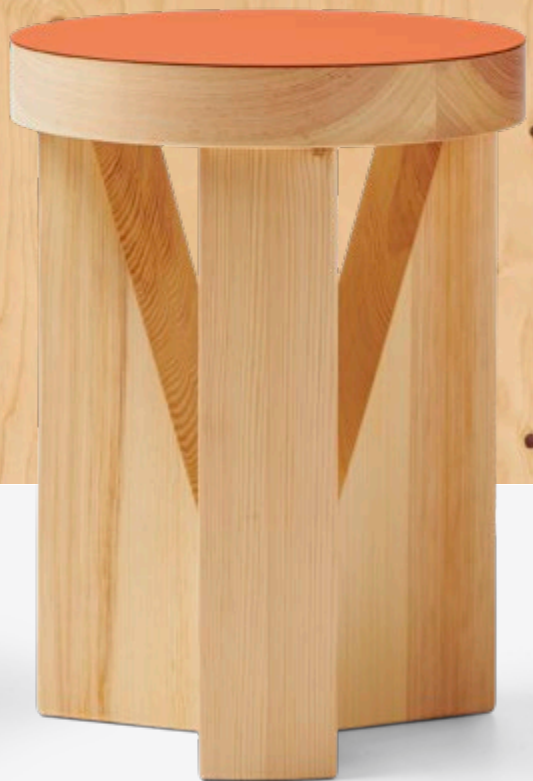



CUGINO SOFT
natural wax on pine,
pistachio linoleum top

CUGINO SOFT
natural wax on pine,
burgundy linoleum top

CUGINO SOFT
natural wax on pine,
orange blast linoleum top

CUGINO STOOL

· Oak frame

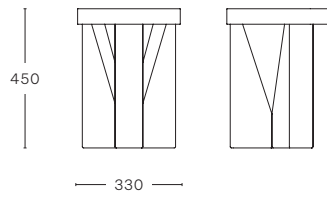

CUGINO SOFT

· Pine frame with FORBO Desktop® Linoleum seat

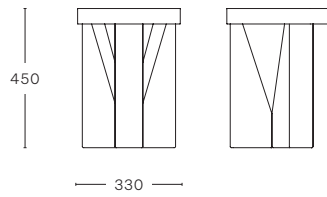

MATERIALS

FRAME

Oak



Natural



Black
RAL 9005

Pine



Natural

SEAT

FORBO Desktop® Linoleum



Burgundy
4154



Pistachio
4183

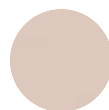

Powder
4185



Orange Blast
4186



REF. #0282

Architecture: Flooat Inc. Photography: Tomooki Kengaku



REF. #0433

Photography: Yupin Oko



REF. #0406

Architecture: Visual Display Photography: Camilla Bach



FRONDA STOOL
black aniline on pine,
fabric seat upholstery

FRONDA Sam Hecht & Kim Colin



FRONDA CHAIR
natural wax on pine,
fabric seat upholstery



FRONDA STOOL
grey aniline on pine,
silver coated steel seat

FRONDA STOOL
black aniline on pine,
black coated steel seat

FRONDA CHAIR
natural wax on pine,
copper coated steel seat



FRONDA CHAIR
grey aniline on pine,
silver coated steel seat



FRONDA STOOL
natural wax on pine,
black coated steel seat



FRONDA TABLE 240
natural wax on pine,
Nero Ingo Fenix NTM® top

FRONDA CHAIR

- Natural pine frame with black or green steel seat
- Black pine frame with black steel seat
- Natural pine frame with silver or copper steel seat
- Grey pine frame with silver steel seat
- Pine frame with non removable upholstery:
- Kvadrat Planum

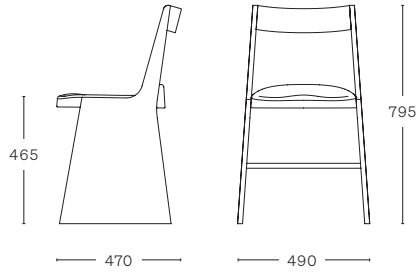

FRONDA LOW STOOL

- Natural pine frame with black or green steel seat
- Black pine frame with black steel seat
- Natural pine frame with silver or copper steel seat
- Grey pine frame with silver steel seat
- Pine frame with non removable upholstery:
- Kvadrat Planum

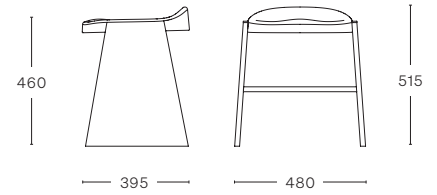

FRONDA TABLE

- Sizes:
- 2000 x 900 mm
 - 2400 x 900 mm with 4 x EU socket outlet

- Natural pine frame with FENIX NTM® top

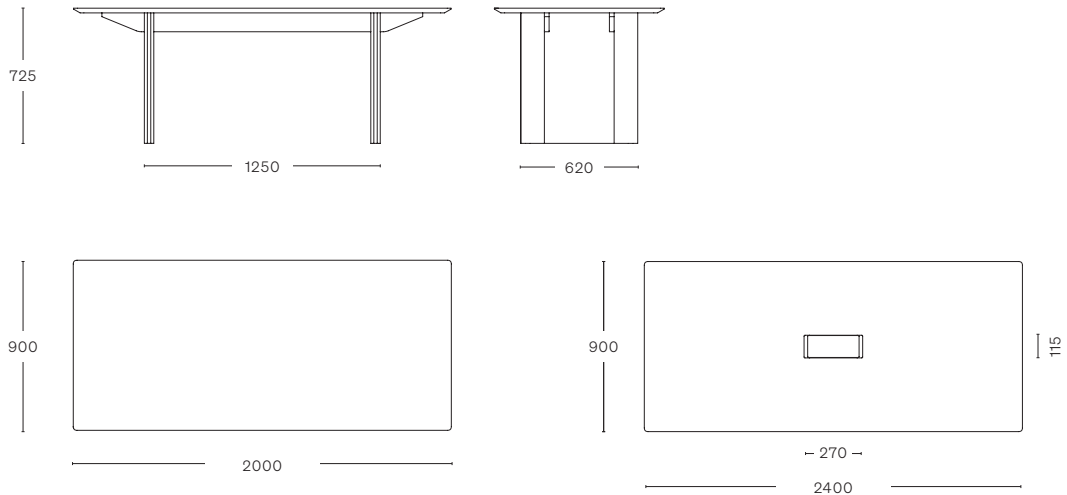

- Bachmann Connect Line 4 x socket outlet

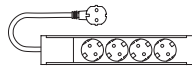

MATERIALS

FRAME Pine



Natural Black* Grey* Black Silver Copper Green
RAL 9005 NCS 4000 RAL 9011 RAL 6005

SEAT Steel

UPHOLSTERY Kvadrat Planum

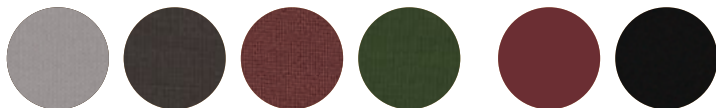

0111 0271 0571 0961 Rosso Jaipur Nero Ingo

TABLE TOP FENIX NTM® top

*not for Fronda Table



REF. #0401

Architecture: Agata Kurzela Studio Photography: Sebastian Böttcher



REF. #0292

Architecture: VSHD Design Photography: Oculis Project



REF. #0401

Architecture: Agata Kurzela Studio Photography: Sebastian Böttcher



ZAMPA ARMCHAIR
yellow aniline on ash

ZAMPA Jasper Morisson



ZAMPA CHAIR
black aniline on ash





ZAMPA CHAIR
natural wax on ash

ZAMPA CHAIR
red aniline on ash

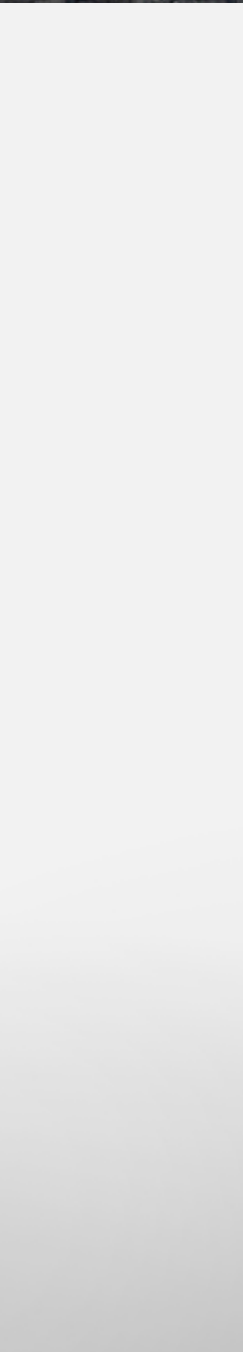

ZAMPA ARMCHAIR
natural wax on ash,
leather seat upholstery



ZAMPA LOW STOOL
neon blue aniline on ash

ZAMPA COUNTER STOOL
neon blue aniline on ash

ZAMPA LOW STOOL
natural wax on ash

ZAMPA COUNTER STOOL
natural wax on ash



ZAMPA BAR STOOL
walnut stain on ash

ZAMPA LOW STOOL
red aniline on ash

ZAMPA CHAIR

- Ash frame
- Ash frame with non removable upholstery:
- Kvadrat Canvas 2
- Sørensens Dunes®

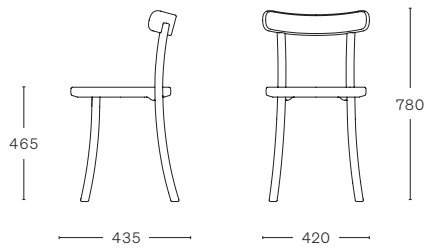

ZAMPA ARMCHAIR

- Ash frame
- Ash frame with non removable upholstery:
- Kvadrat Canvas 2
- Sørensens Dunes®

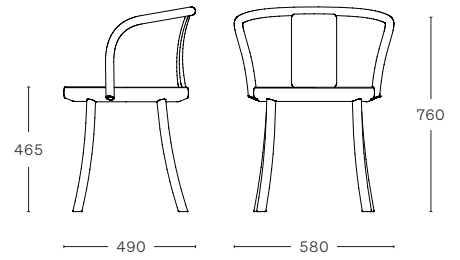

ZAMPA LOW STOOL

- Ash frame

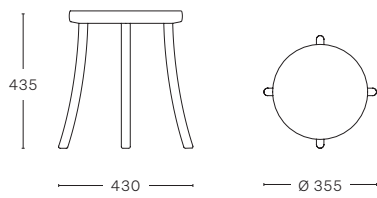

ZAMPA COUNTER STOOL

- Ash frame

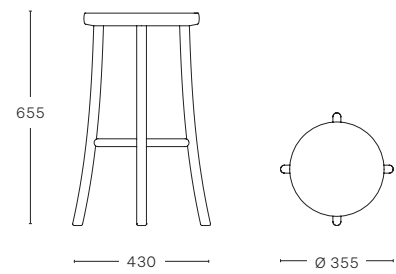

ZAMPA BAR STOOL

- Ash frame

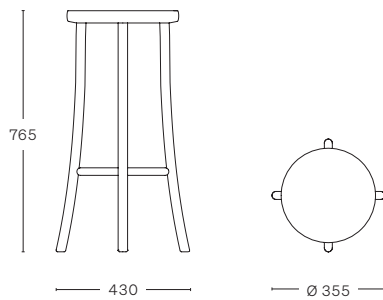

MATERIALS

FRAME

Ash

UPHOLSTERY

Kvadrat Canvas 2

Sørensens Dunes®

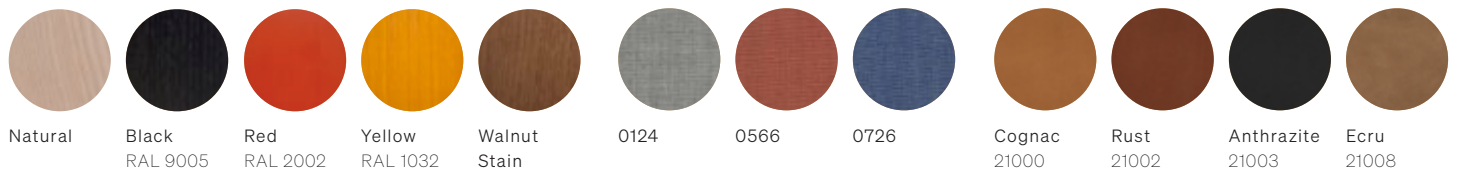



REF. #0392

Architecture: Studio 103 & McCormack Photography: Emily Bartlett



REF. #0308

Architecture: Studio Framer Photography: Yongjun Choi



REF. #0400

Architecture: Marialaura Irvine Photography: Natalia Garcia



FORCINA TABLE
black coated stainless
steel frame,
black aniline on ash top

FORCINA Leon Ransmeier



FORCINA CHAIR
black coated stainless
steel frame,
black aniline on ash seat
and backrest



FORCINA ARMCHAIR
black coated stainless
steel frame,
black aniline on ash seat
and backrest





FORCINA BAR STOOL
black coated stainless
steel frame,
natural wax on ash seat

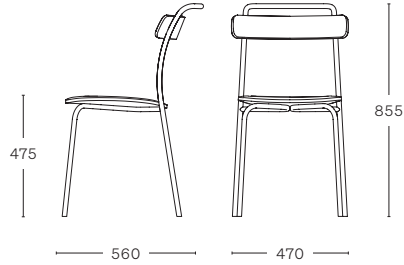

FORCINA CHAIR

- Black Stainless Steel frame
- Ash
- Oak
- Robinia
(for outdoor use)
- Brushed Stainless Steel frame
- Ash
- Oak
- Robinia
(for outdoor use)



Stackable x3 

FORCINA ARMCHAIR

- Black Stainless Steel frame
- Ash
- Oak
- Robinia
(for outdoor use)
- Brushed Stainless Steel frame
- Ash
- Oak
- Robinia
(for outdoor use)

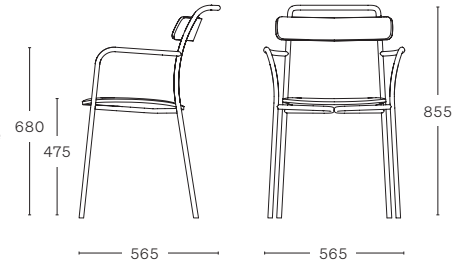

Stackable x3 

FORCINA LOW STOOL

- Black Stainless Steel frame
- Ash
- Oak
- Robinia
(for outdoor use)
- Brushed Stainless Steel frame
- Ash
- Oak
- Robinia
(for outdoor use)

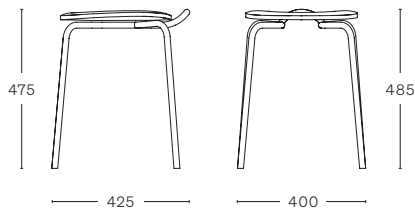

Stackable x3 

FORCINA BAR STOOL

- Black Stainless Steel frame
- Ash
- Oak
- Robinia
(for outdoor use)
- Brushed Stainless Steel frame
- Ash
- Oak
- Robinia
(for outdoor use)

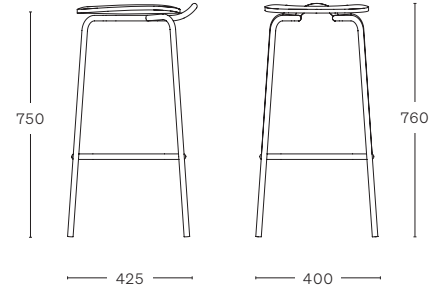

FORCINA TABLE

- Sizes:
- 700 x 700 mm
 - Ø 800 mm (round)

- Black Stainless Steel frame
- Ash
- Oak
- Robinia
(for outdoor use)
- Brushed Stainless Steel frame
- Ash
- Oak
- Robinia
(for outdoor use)

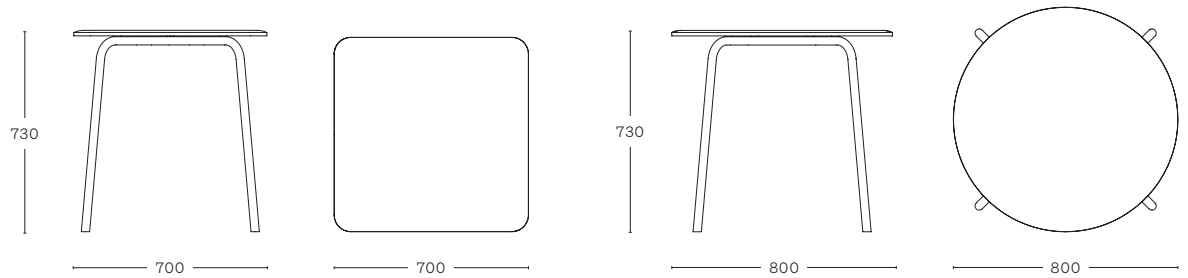

MATERIALS

SEAT AND BACK

Ash



Natural



Black
RAL 9005

Oak



Natural

Robinia



Oiled

FRAME

Stainless Steel frame



Black



Brushed



REF. #0264

Photography: Gerhardt Kellermann



REF. #0314

Architecture: Marco Zito & Artico Fracassi | Photography: Marco Cappelletti



QUINDICI LOUNGE
natural wax on ash,
leather upholstery

QUINDICI Ronan & Erwan Bouroullec





QUINDICI CHAISE LONGUE
grey aniline on ash, fabric upholstery





QUINDICI LOUNGE UPHOLSTERY

- Ash frame with removable upholstery:
- Kvadrat Divina 3
- Dani Lord Leather

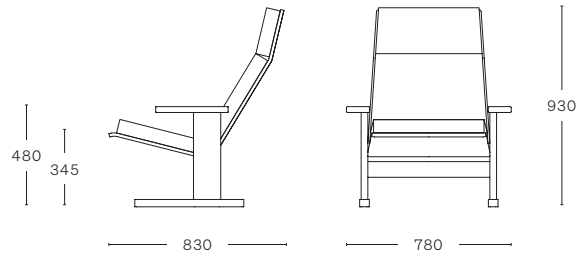

QUINDICI CHAISE LONGUE UPHOLSTERY

- Ash frame with removable upholstery:
- Kvadrat Divina 3
- Dani Lord Leather

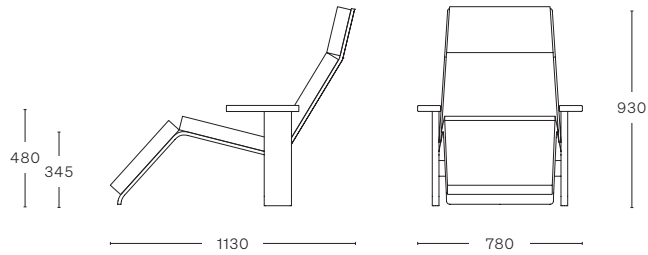

MATERIALS

FRAME

Ash



Natural

Grey

Black

RAL 7046

RAL 9005

UPHOLSTERY

Kvadrat Divina 3

Dani Lord Leather



191



9300



REF. #0222
Photography: Valentina Sommariva



REF. #0420
Photography: LICHT Gallery Showroom



PRIMO CHAIR
natural wax on oak,
leather seat upholstery

PRIMO TABLE 180
natural wax on oak,
oak veneered top

PRIMO Konstantin Grcic





PRIMO CHAIR
black aniline on beech



PRIMO CHAIR
gold lacquer on beech



PRIMO BAR STOOL
natural wax on beech,
brushed aluminum footrest



PRIMO CHAIR
natural wax on beech

PRIMO CHAIR

- Beech frame
- Gold beech frame
- Oak frame with non removable upholstery:
 - Dani Acquario Leather
 - Sweet Leather

Stackable x3 

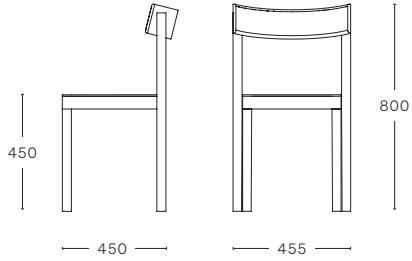

PRIMO COUNTER STOOL

- Beech frame
- Oak frame with non removable upholstery:
 - Dani Acquario Leather
 - Sweet Leather

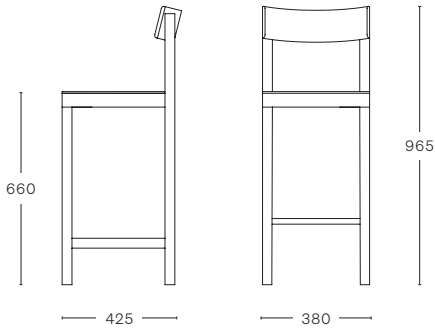

PRIMO BAR STOOL

- Beech frame
- Oak frame with non removable upholstery:
 - Dani Acquario Leather
 - Sweet Leather

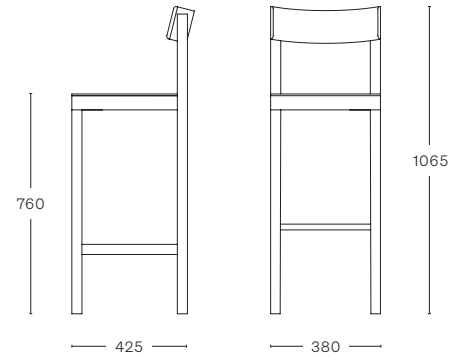

PRIMO TABLE

- Sizes:
- 900 × 900 mm
 - 1800 × 900 mm

- Natural oak frame
- Oak veneered top
- FENIX NTM® top

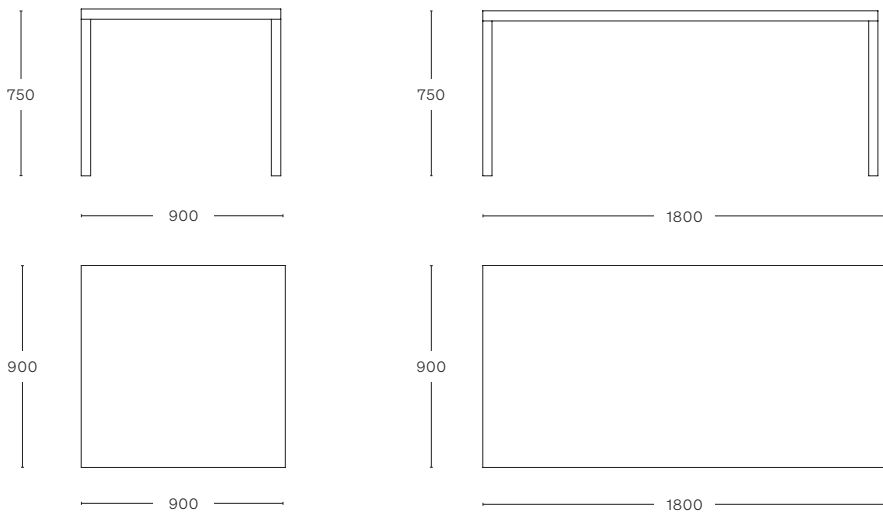

MATERIALS

FRAME

Beech



Natural



Black
RAL 9005



Gold*

Oak



Natural

UPHOLSTERY

Dani Acquario Leather



Cuoio



Marrone

Sweet Leather



508



510



512

TABLE TOP

FENIX NTM® top



Castoro
Ottawa



Nero Ingo

*not for Primo Counter & Bar Stool



REF. #0429

Architecture: Spacegram Studio Photography: Francisco Nogueira



REF. #0339

Architecture: Flooat Inc. Photography: Tomooki Kengaku



REF. #0247

Architecture: Maximilian Gottwald Photography: Maximilian Gottwald



FACILE BENCH 180
natural wax on ash

FACILE TABLE 180
natural wax on ash

FACILE Lambl / Homburger



FACILE BENCH

Sizes:
- 1180 × 350 mm
- 1800 × 350 mm

· Natural Ash frame

· Black Ash frame

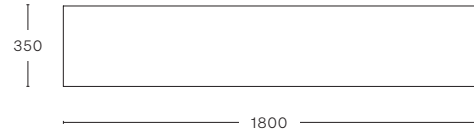
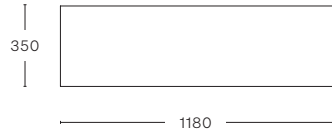
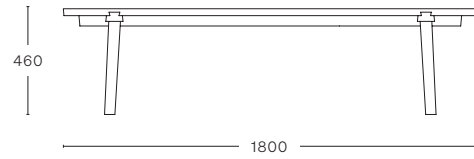
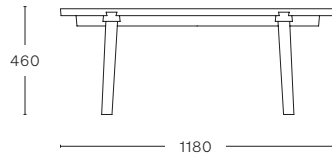

FACILE TABLE

Sizes:
- 1800 × 900 mm
- 2400 × 900 mm

· Natural Ash frame

· Black Ash frame

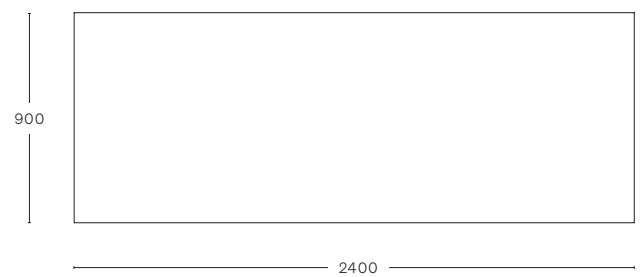
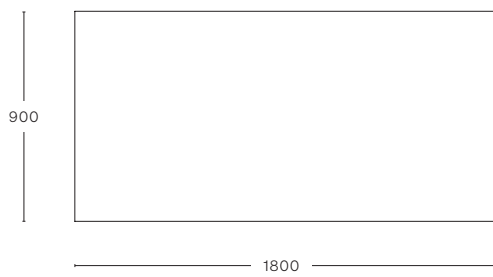
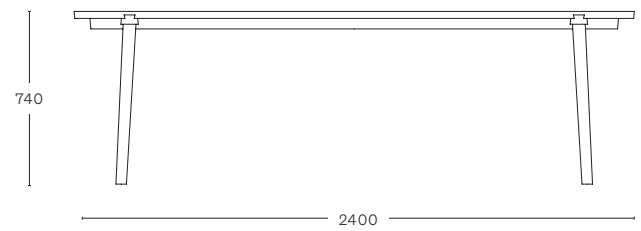
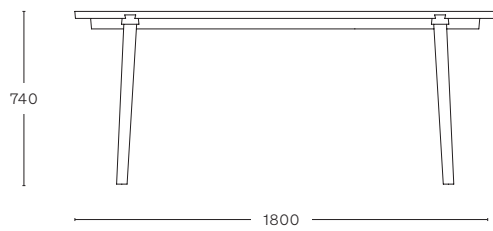

MATERIALS

FRAME

Ash

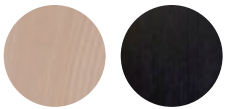

Natural

Black
RAL 9005



REF. #0252

Photography: Frau Boutique



REF. #0413

Architecture: Studio AC Photography: Felix Michaud



TRONCO CHAIR
natural wax on ash,
fabric upholstery

TRONCO Sam Hecht & Kim Colin



TRONCO CHAIR
walnut stain on ash



TRONCO CHAIR
green aniline on ash,
fabric upholstery





TRONCO CHAIR
white aniline on ash



TRONCO CHAIR

- Ash frame
- Ash frame with non removable upholstery:
- Rohi Topia

Stackable ×5



Stackable on dolly ×10

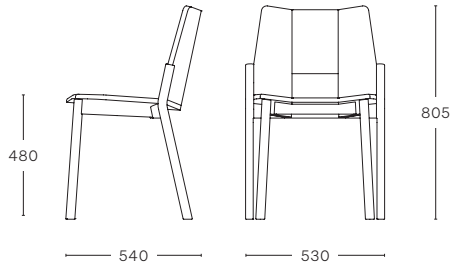

TRONCO TABLE

- Ash frame

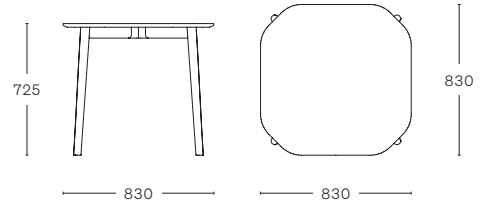

TRONCO CONNECTOR

- Plastic Connector

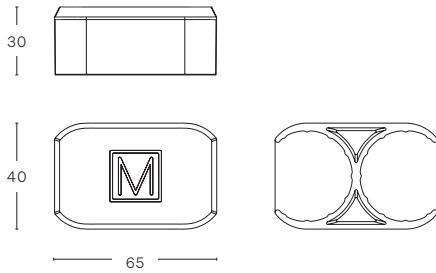

- Row Connector
- Plastic PA6 + 30% Glass Fiber

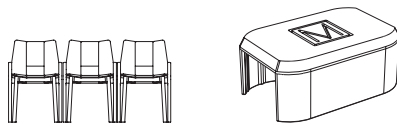

TRONCO DOLLY

- Powder coated metal

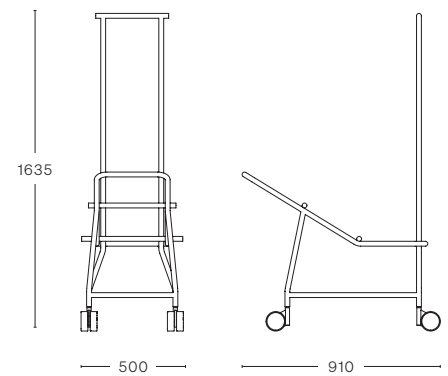

MATERIALS

FRAME

Ash



Natural Black RAL 9005 White RAL 9003 Walnut Stain Chestnut Stain Red* RAL 2002 Green* RAL 6007

DOLLY FRAME

Powder Coated Metal



White RAL 9003 Black RAL 9005

PLASTIC CONNECTOR

Mat Plastic

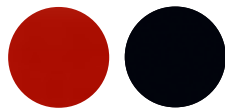

Red RAL 3020 Black RAL 8022

UPHOLSTERY

Rohi Topia



Ebony Walnut Moon Chili Palm

*not for Tronco Table



REF. #0396
Photography: Kate Bowman



REF. #0293
Architecture: Sayes Studio Photography: Samuel Hartnett



REF. #0019
Architecture: Antonio Guacci Photography: Gerhardt Kellermann



REF. #0338
Photography: Zoe Liao



CLERICI LOUNGE
red aniline on ash

CLERICI Konstantin Grcic



CLERICI LOUNGE
natural wax on oak

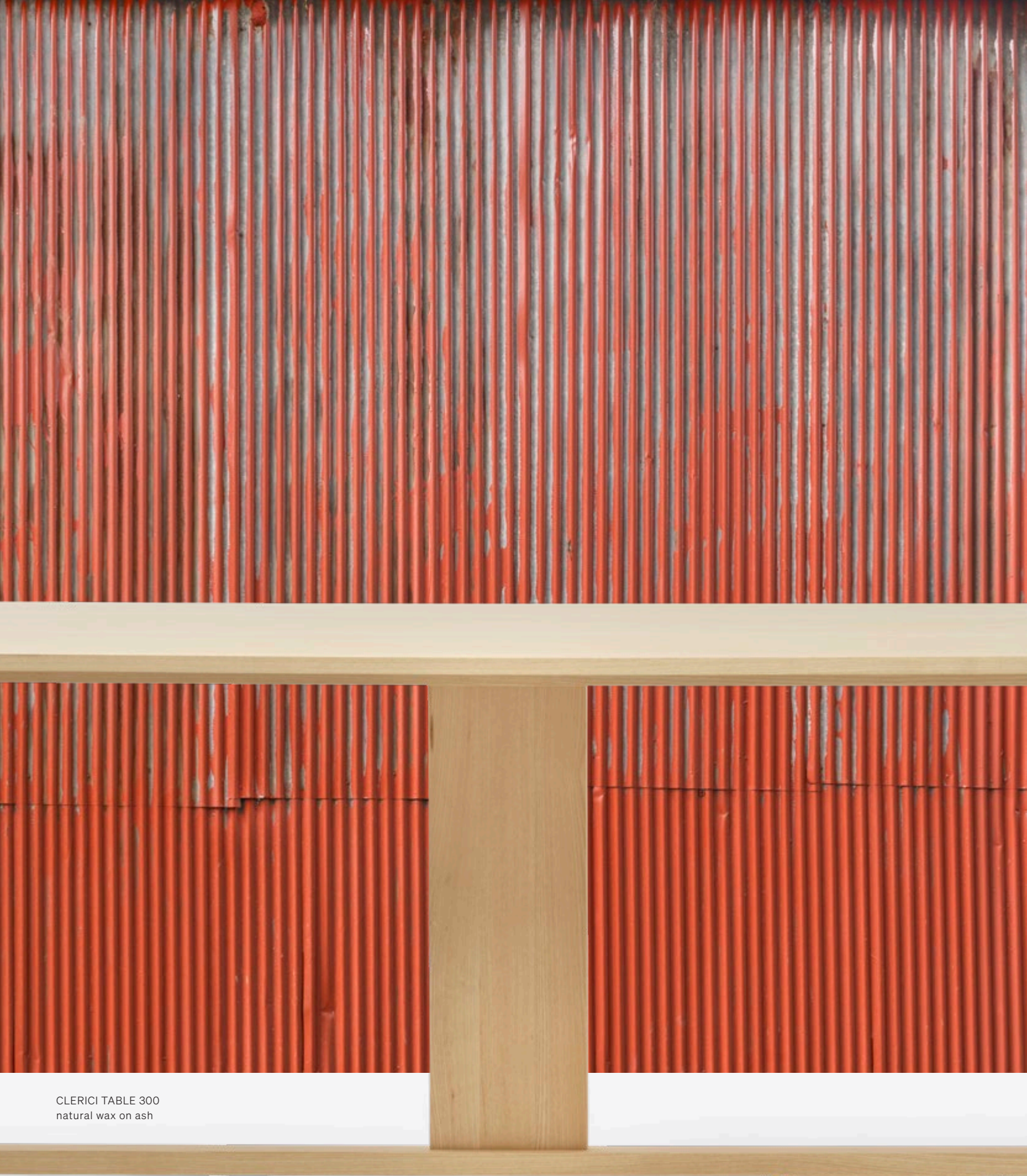

CLERICI TABLE 300
natural wax on ash



M

C

10



CLERICI 2 SEATER
natural wax on oak,
leather seat upholstery



CLERICI LOUNGE

Sizes:
- One Seat
- 2 Seater

· Ash frame
· Oak frame

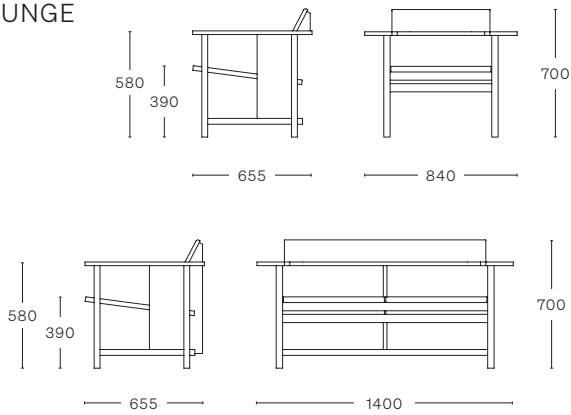

CLERICI LOUNGE

UPHOLSTERY

Sizes:
- One Seat
- 2 Seater

· Oak frame with
non removable
upholstery:
- Dani Acquario
Leather

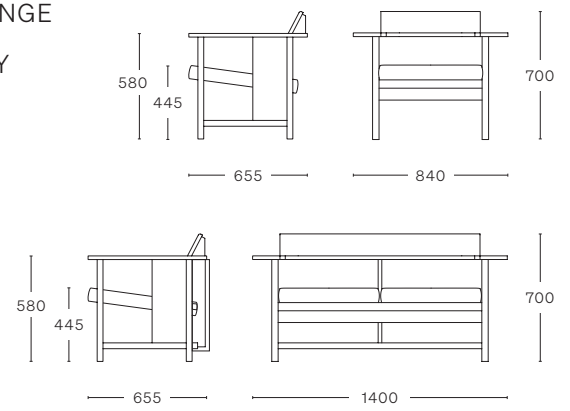

CLERICI BENCH

Size:
- 3 Seater

· Ash frame

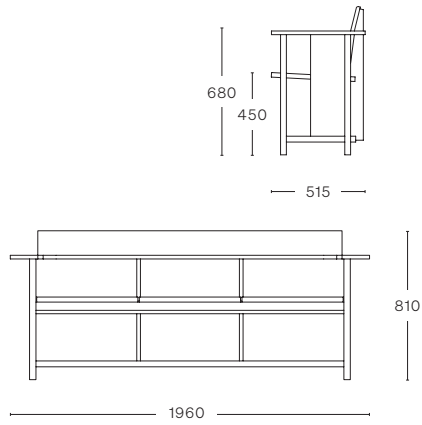

CLERICI TABLE

(OUTDOOR)

Size:
- 1110 x 555 m

· Iroko (for outdoor use)

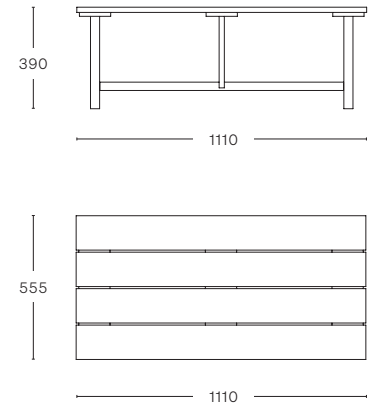

CLERICI TABLE

Sizes:
- 2400 x 1000 mm
- 3000 x 1000 mm

· Natural ash

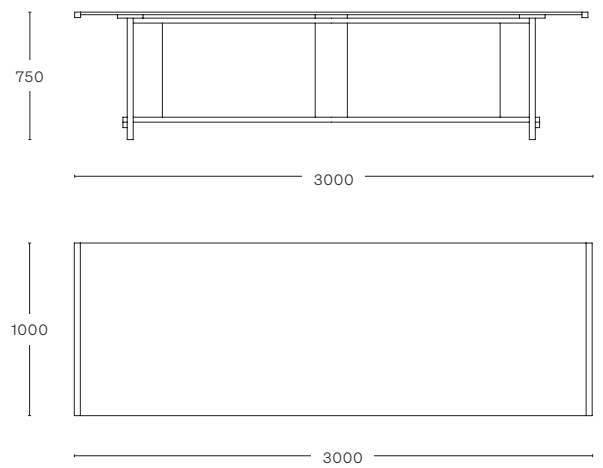
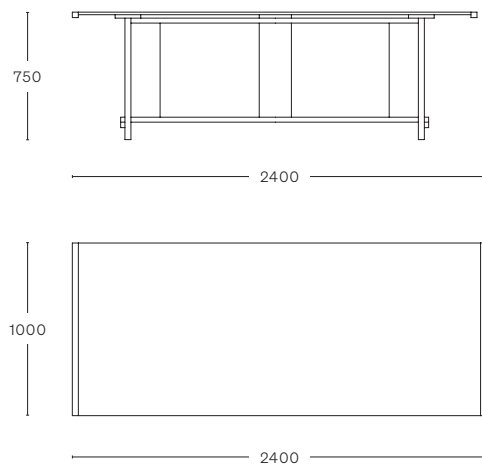

MATERIALS

FRAME

Ash



Natural



Grey
RAL 7031



Red
RAL 2002

Oak



Natural

Iroko



Oiled

UPHOLSTERY

Dani Acquario Leather



Cuoio



Marrone



REF. #0248

Architecture: Aspekt Office Photography: Rasmus Dengsø



REF. #0220

Architecture: Kollekted By Photography: Inger Marie Grini



REF. #0450

Architecture: Archiplan Studio Photography: Nicolò Panzeri



UNCINO VERSION C
black coated steel frame,
black aniline on ash seat
and backrest

UNCINO Ronan & Erwan Bouroullec



UNCINO VERSION A
black coated steel frame,
black aniline on ash seat and backrest

UNCINO VERSION B
black coated steel frame,
black aniline on ash seat and backrest



UNCINO VERSION B
black coated steel frame,
natural wax on ash seat
and backrest





UNCINO BAR STOOL
natural wax on ash,
black coated steel base
and footrest

UNCINO VERSION A

· Ash

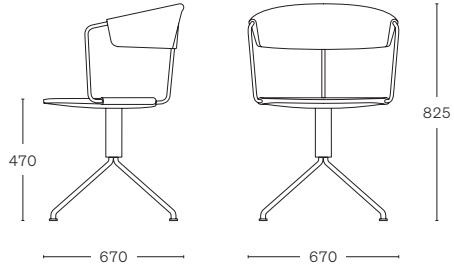

UNCINO VERSION B

· Oak

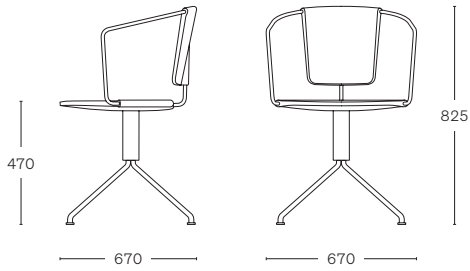

UNCINO VERSION C

· Ash

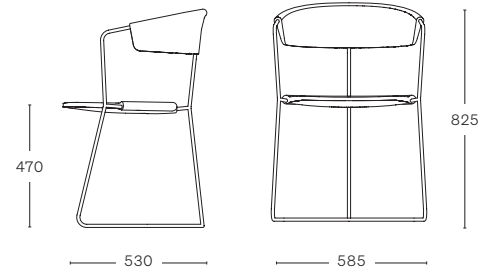

UNCINO BAR STOOL

· Ash

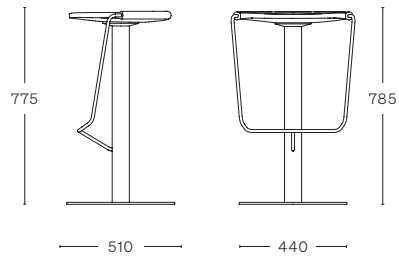

MATERIALS

SEAT AND BACK

Ash

Oak

FRAME

Metal Frame



Natural

Black
RAL 9005

Natural

Black



REF. #0199
Architecture: Winwood McKenzie Photography: Ben Hosking



REF. #0339
Architecture: Flooat Inc. Photography: Tomoki Kengaku



REF. #0333
Photography: Gerhardt Kellermann

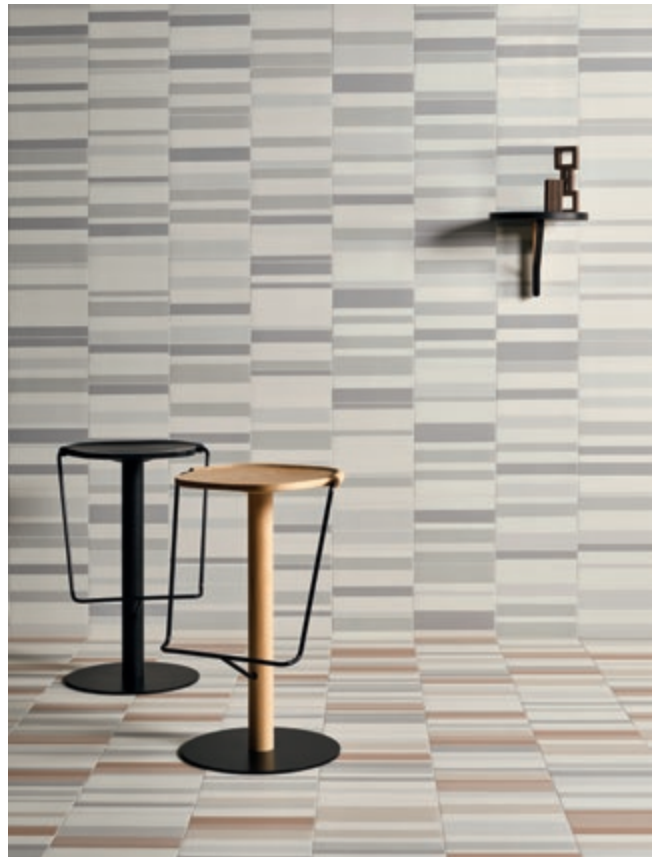

REF. #0178
Photography: Gerhardt Kellermann



CHIARO ARMCHAIR
natural wax on ash,
fabric seat upholstery

CHIARO Leon Ransmeier





CHIARO CHAIR
natural wax on ash



CHIARO BAR STOOL
dark red aniline on ash,
brushed stainless steel footrest

CHIARO CHAIR

- Ash frame
- Ash frame with non removable upholstery:
 - Rohi Novum
- Oak frame
- Oak frame with non removable upholstery:
 - Rohi Novum

Stackable x3 

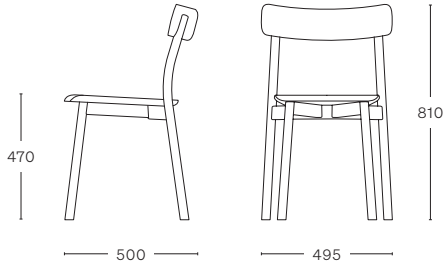

CHIARO ARMCHAIR

- Ash frame
- Ash frame with non removable upholstery:
 - Rohi Novum
- Oak frame
- Oak frame with non removable upholstery:
 - Rohi Novum

Stackable x3 

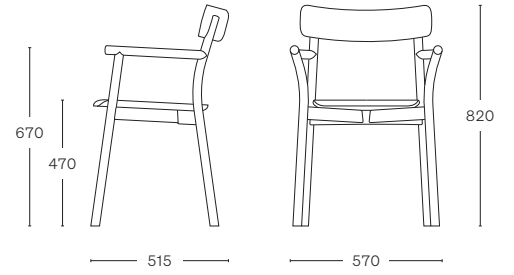

CHIARO COUNTER STOOL

- Ash frame

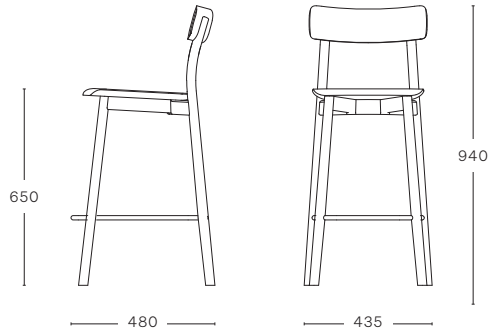

CHIARO BAR STOOL

- Ash frame

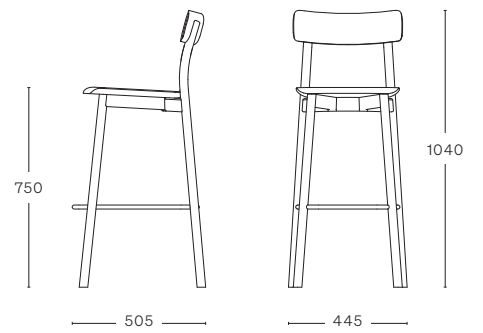

MATERIALS

FRAME

Ash



Natural Black RAL 9005 White RAL 9003 Grey RAL 7031 Blue RAL 5007 Dark Red RAL 3009 Yellow RAL 1032

Oak



Natural

FOOTREST

Metal



Brushed

UPHOLSTERY

Rohi Novum

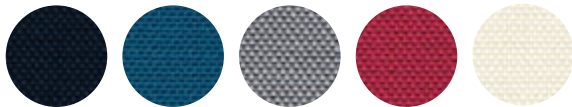

Amur Azur Kies Magenta Snow



REF. #0391

Architecture: Matt Crawford Architects Photography: Dion Robeson



REF. #0407

Architecture: Studio Whiting Photography: Jack Shelton



REF. #0272

Architecture: akkurat bauatelier AG Photography: Damian Poffet



RADICE Sam Hecht & Kim Colin



RADICE CHAIR
natural wax on ash



RADICE COUNTER STOOL
black aniline on ash





RADICE COUNTER STOOL
red aniline on ash,
fabric seat upholstery

RADICE CHAIR

- Ash frame
- Removable upholstery:
 - Rohi Novum
 - Sweet Leather

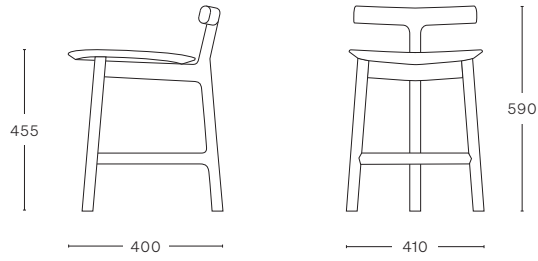

RADICE COUNTER STOOL

- Ash frame
- Removable upholstery:
 - Rohi Novum
 - Sweet Leather

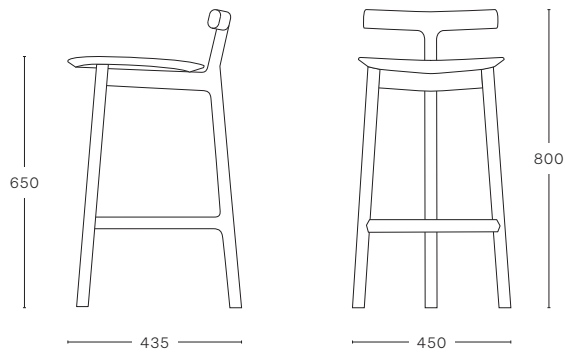

MATERIALS

FRAME

Ash



Natural



Black
RAL 9005



Red
RAL 2002



Green
RAL 6007



Yellow
RAL 1033

UPHOLSTERY

Rohi Novum



Sunset

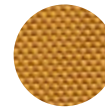

Curry

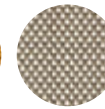

Cocos

Sweet Leather



Dark Brown
511



Black
569



REF. #0296

Architecture: Note Design Studio Photography: Joakim Johansson



REF. #0294

Architecture: XForma Photography: Alexander Volodin



REF. #0084

Architecture: Ester Bruzkus Architekten Photography: Jens Bösenberg



REF. #0278

Architecture: Note Design Studio Photography: Simon Bevan

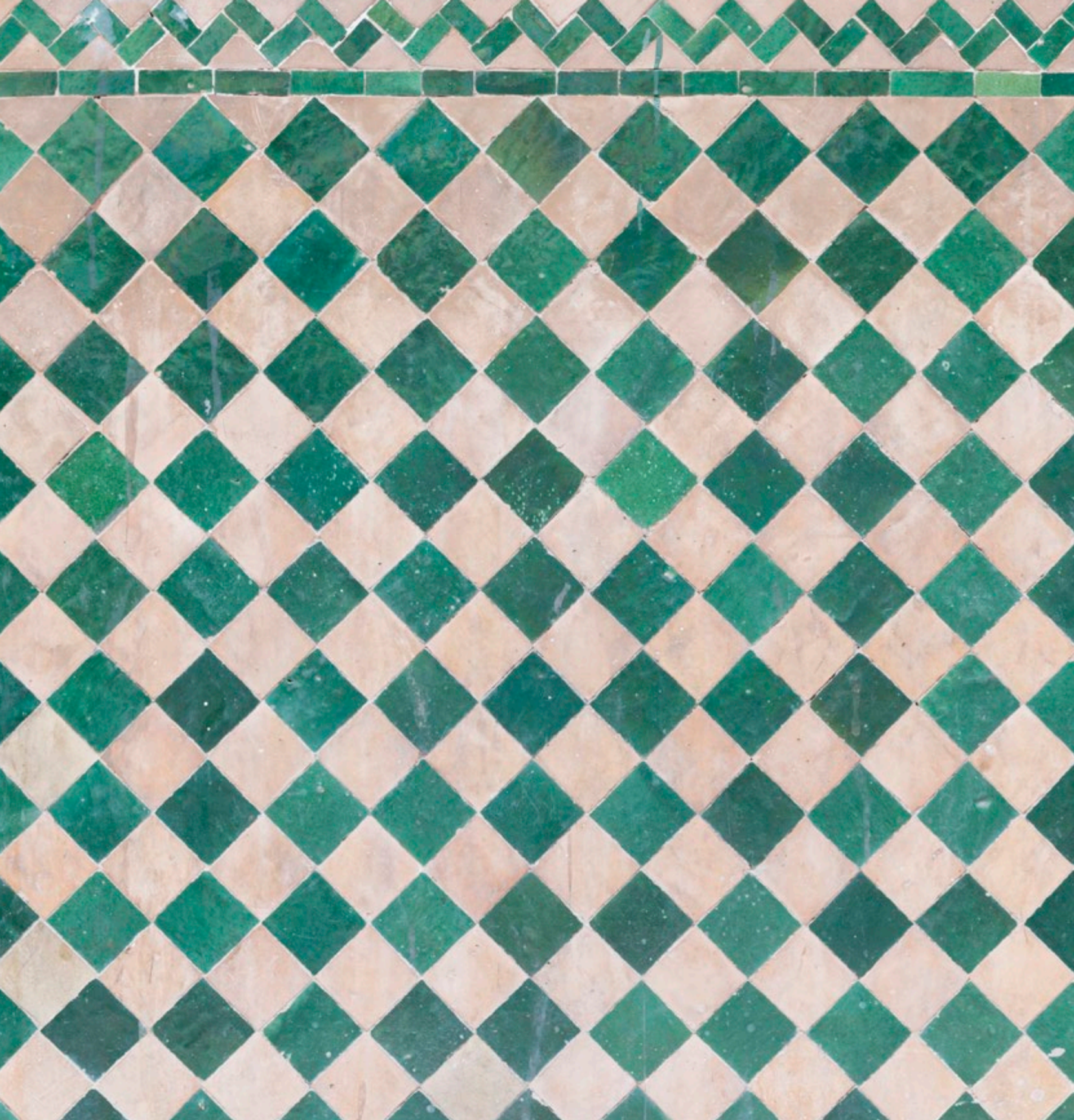

FIONDA Jasper Morrison



FIONDA
black aniline on ash,
fabric upholstery

FIONDA SIDE CHAIR

- Black ash frame with removable canvas covers:
 - Natural Canvas
 - Orange Canvas

Nesting x5 

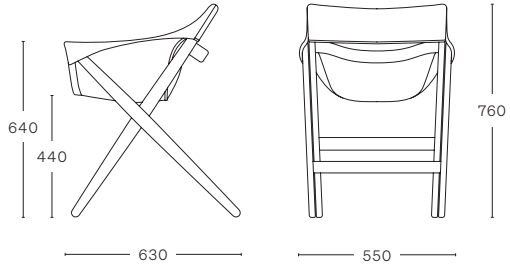

MATERIALS

FRAME

Ash



Black
RAL 9005

UPHOLSTERY

Canvas



Natural



Orange



REF. #0058

Architecture: Arent&Pyke Photography: James Whineray



SOLO CHAIR
natural wax on ash

SOLO Studio Nitzan Cohen



SOLO CHAIR
neon blue aniline on ash

SOLO SQUARE TABLE
neon blue aniline on ash





SOLO BAR STOOL
natural wax on oak,
grey coated steel footrest

SOLO COUNTER STOOL
dark red aniline on ash,
leather seat upholstery,
red coated steel footrest

SOLO LOW STOOL
turquoise aniline on ash,
white coated steel footrest

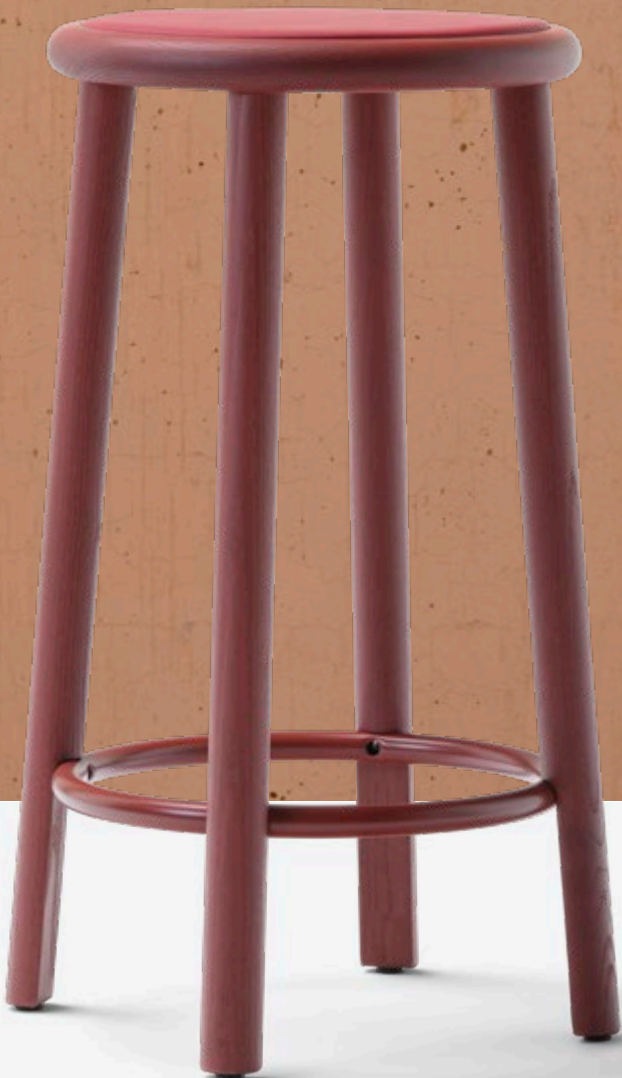

M

C

5



SOLO CHAIR
black/blue aniline on ash,
leather seat upholstery



SOLO CHAIR
natural wax on ash

SOLO TABLE
natural wax on ash



SOLO CHAIR

- Ash frame
- Ash frame with non removable upholstery:
 - Sweet Leather
- Oak frame
- Oak frame with non removable upholstery:
 - Sweet Leather

Stackable x3 

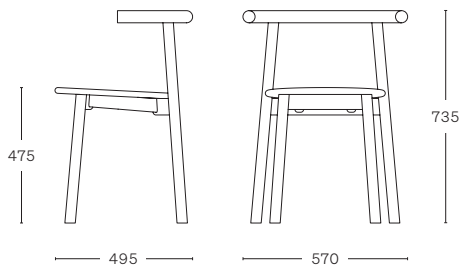

SOLO LOW STOOL

- Ash frame
- Oak frame

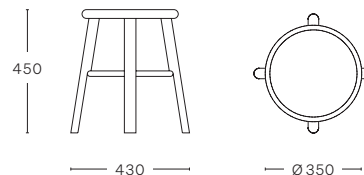

SOLO COUNTER STOOL

- Ash frame
- Oak frame
- Bicolour on oak

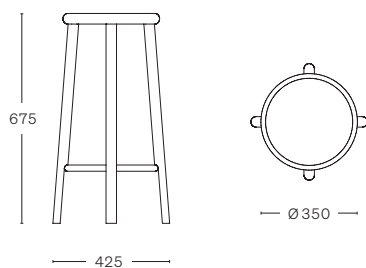

SOLO BAR STOOL

- Ash frame
- Oak frame
- Bicolour on oak

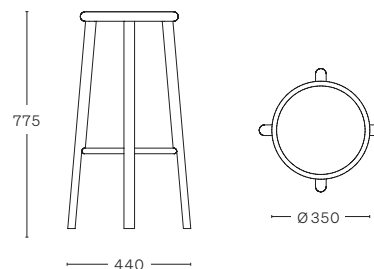

SOLO TABLE

- Sizes:
- 650 x 650 mm
 - Ø 650 mm (round)

- Ash frame
- Oak frame

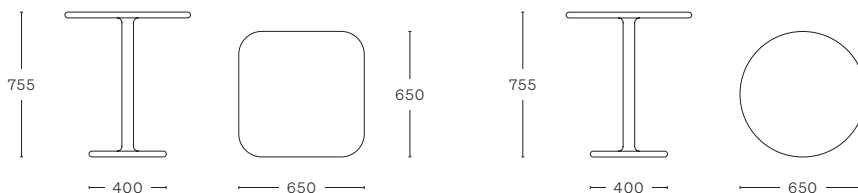

MATERIALS

FRAME



FOOTREST



UPHOLSTERY



*not for Solo Low Stool



REF. #0250

Architecture: Aires Mateus Photography: Maria Masià & Rui Cardoso



REF. #0430

Architecture: Gregorio Pecorelli Photography: Francesca Iovene



REF. #0340

Architecture: Rezen Studio Photography: Jack Lovel



REF. #0321

Architecture: Aires Mateus Photography: Francisco Nogueira



MEDICI LOUNGE
grey aniline on ash

MEDICI Konstantin Grcic



MEDICI STOOL
yellow aniline on ash



MEDICI TABLE
red aniline on ash

MEDICI LOUNGE
red aniline on ash

MEDICI STOOL
red aniline on ash



MEDICI LOUNGE
natural wax on ash

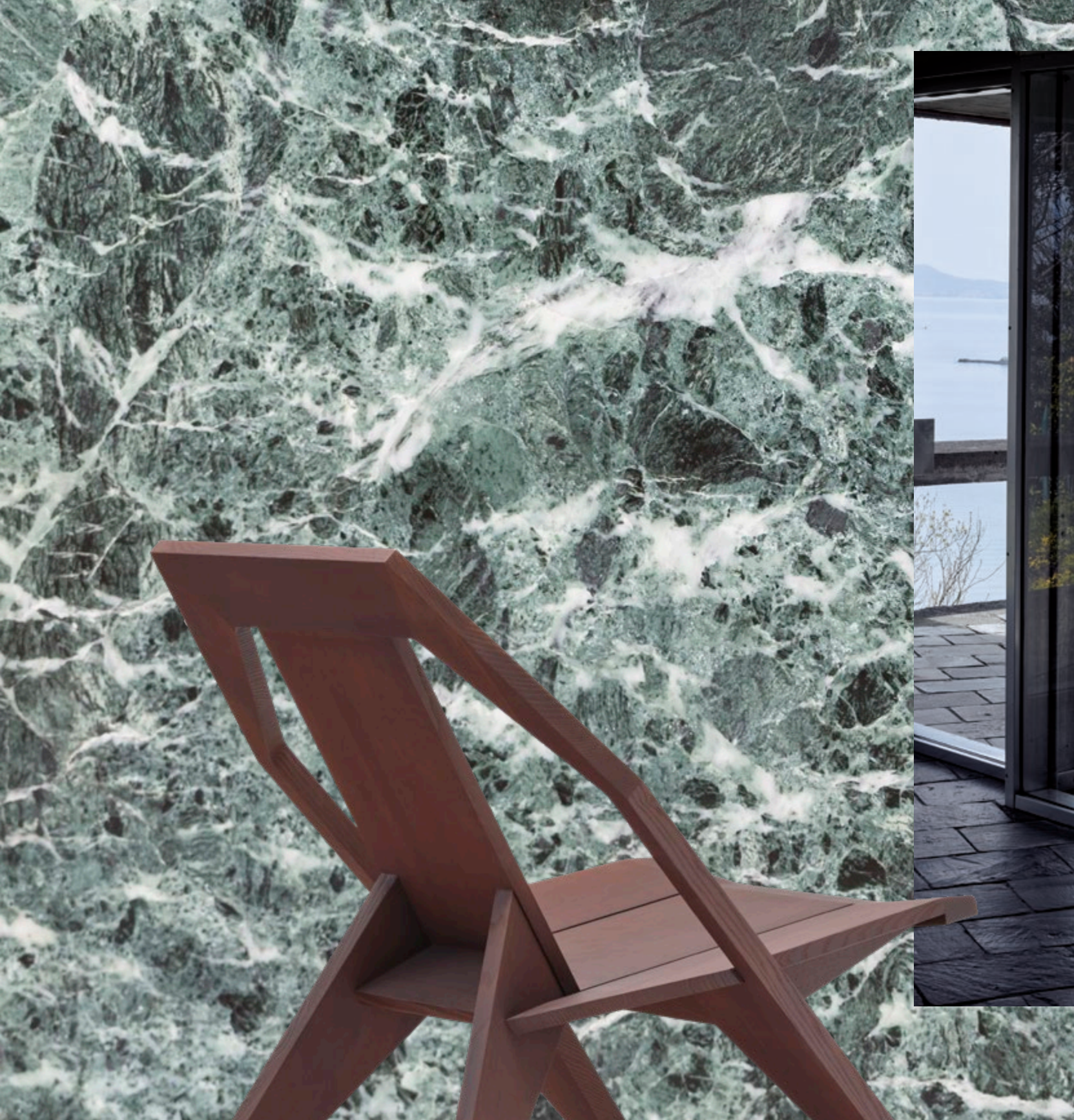

MEDICI LOUNGE
thermo-treated ash



MEDICI TABLE
thermo-treated ash



MEDICI LOUNGE

- Ash frame
- Thermo ash frame oiled (for outdoor use)

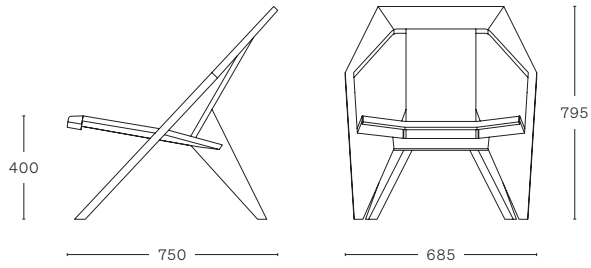

MEDICI TABLE

- Ash frame
- Thermo ash frame oiled (for outdoor use)

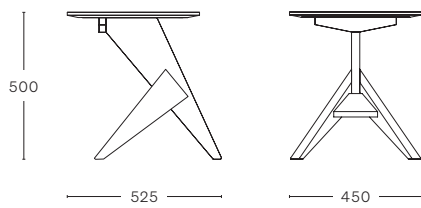

MEDICI STOOL

- Ash frame
- Thermo ash frame oiled (for outdoor use)

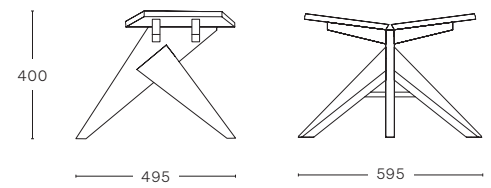

MATERIALS

FRAME

Ash

Thermo Ash



Natural



Black
RAL 9005



Grey
RAL 7031



Yellow
RAL 1018



Red
Pantone 032C

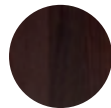

Oiled



REF. #0401

Architecture: Agata Kurzela Studio Photography: Sebastian Böttcher



REF. #0255

Architecture: NEGRE Studio Photography: Mauricio Fuertes

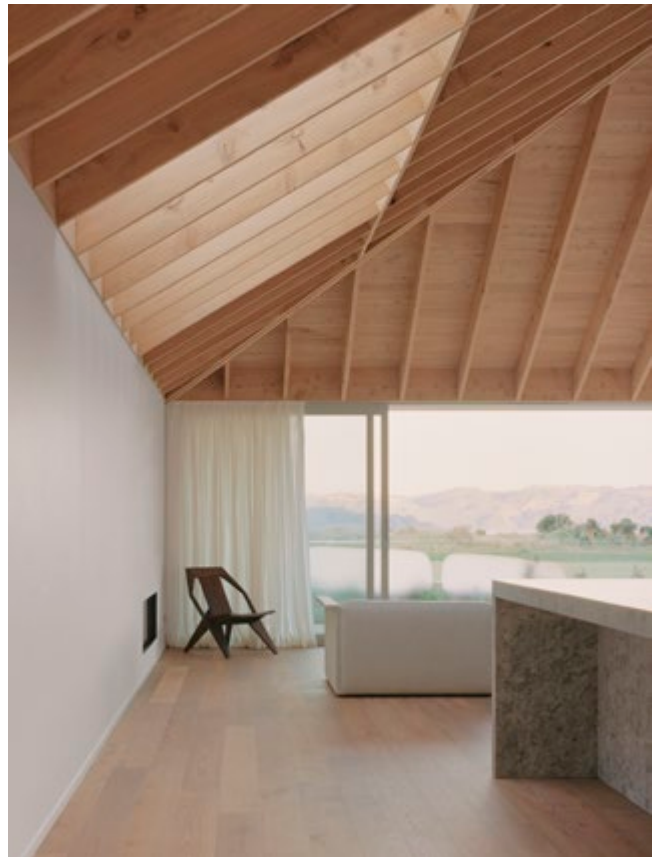

REF. #0411

Architecture: Seear-Budd Ross Photography: Rory Gardiner



OSSO LOW STOOL
grey aniline on ash

OSSO Ronan & Erwan Bouroullec



OSSO CHAIR
pink aniline on ash



OSSO CHAIR
natural wax on oak





OSSO TABLE
grey aniline on ash

M

C

3



OSSO COUNTER STOOL
white aniline on ash



OSSO LOW STOOL
green aniline on ash



OSSO CHAIR

- Ash frame
- Oak frame

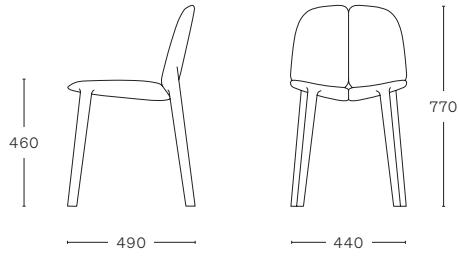

OSSO LOW STOOL

- Ash frame

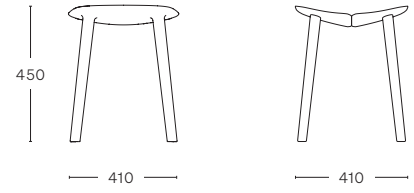

OSSO COUNTER STOOL

- Ash frame
- Oak frame

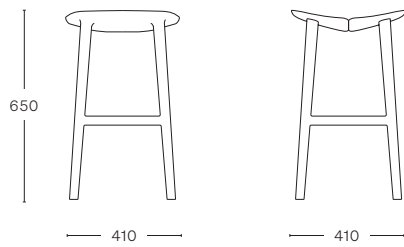

OSSO BAR STOOL

- Ash frame
- Oak frame

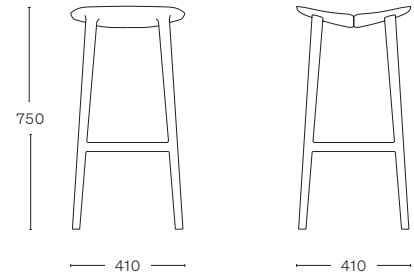

OSSO TABLE

- Sizes:
- 1300 × 800 mm
 - Ø 650 mm (round)

- Ash frame
- Oak frame

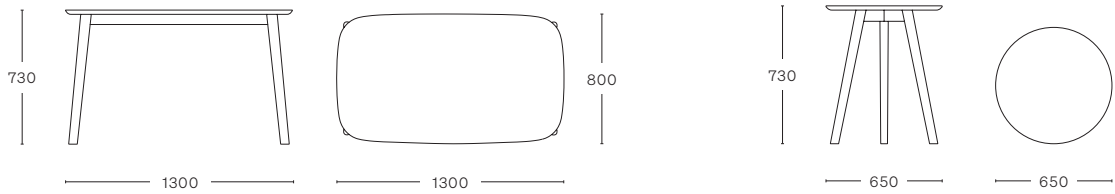

- Size:
- 650 × 650 mm

- Ash frame

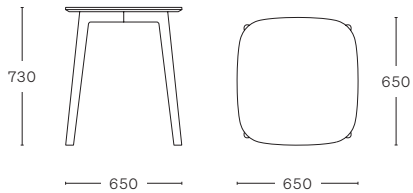

MATERIALS

FRAME

Ash



Natural



Black
RAL 9005



White
RAL 9003



Grey
RAL 7031



Blue
RAL 5008



Pink
WCP 157



Green
RAL 6003

Oak



Natural



REF. #0329

Architecture: Studio Anna Kunst Photography: Rowfotografie



REF. #0415

Architecture: Quattro Uno & Malcom Walker Photography: Samuel Hartnett



REF. #0415

Architecture: Quattro Uno & Malcom Walker Photography: Samuel Hartnett



BRANCA CHAIR
green aniline on ash

BRANCA TABLE
natural wax on ash

BRANCA Sam Hecht & Kim Colin



BRANCA CHAIR
green aniline on ash



BRANCA CHAIR
black aniline on ash,
fabric seat upholstery



BRANCA BAR STOOL
natural wax on ash,
white coated steel footrest

M

C

2

BRANCA CHAIR

- Ash frame
- Removable upholstery:
 - Abi Nord Wool
 - Rohi Novum

Stackable ×3 

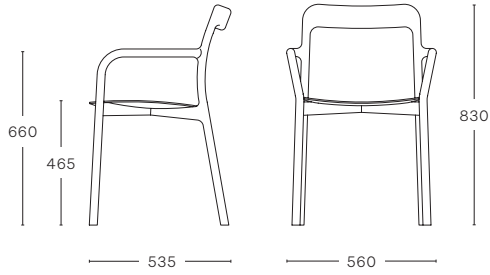

BRANCA COUNTER STOOL

- Ash frame
- Removable upholstery:
 - Rohi Novum

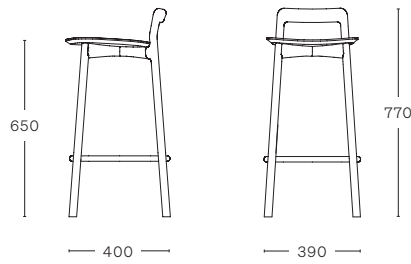

BRANCA BAR STOOL

- Ash frame
- Removable upholstery:
 - Rohi Novum

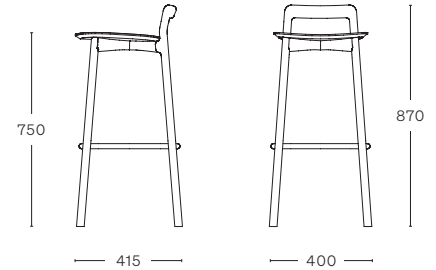

BRANCA TABLE

Size:
- 1500 × 1100 mm

- Ash frame
- MDF top white lacquered
- Ash wood top

Size:
- 1800 × 1100 mm

- Ash frame
- MDF top white lacquered

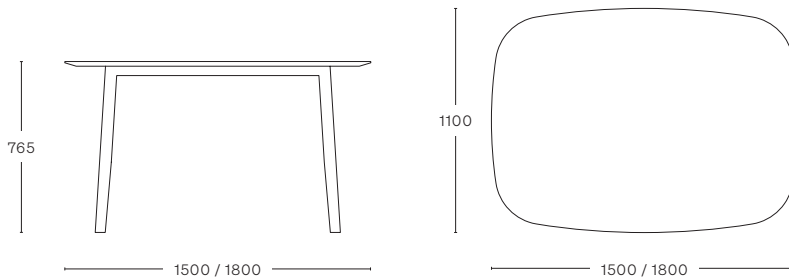

MATERIALS

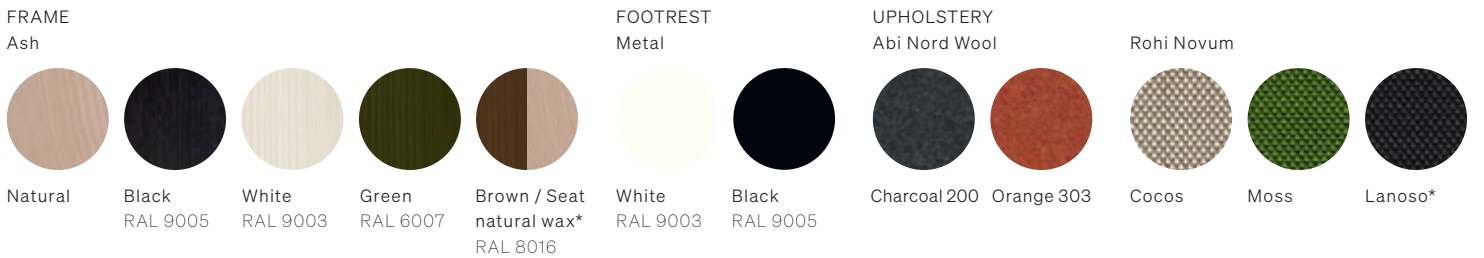

*not for Branca Counter and Bar Stool



REF. #0310

Architecture: VPS Architetti Photography: Studio Vetroblu



REF. #0210

Architecture: Marie Deroudilhe Photography: Julie Ansiau



REF. #0417

Architecture: Unknown Photography: Zoe Liao



SHE SAID LOWIDE
black aniline on ash

HE SAID / SHE SAID STUDIO NITZAN COHEN



SHE SAID CHAIR
black aniline on ash,
fabric seat upholstery



SHE SAID BAR STOOL
neon blue aniline on ash



HE SAID
natural wax on ash

HE SAID CHAIR

- Ash frame
- Ash frame with non removable upholstery:
- Rohi Topia

· Stackable x2 

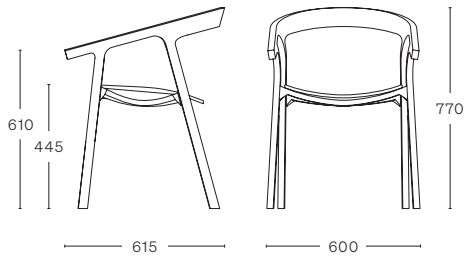

SHE SAID CHAIR

- Ash frame
- Ash frame with non removable upholstery:
- Rohi Topia

· Stackable x2 

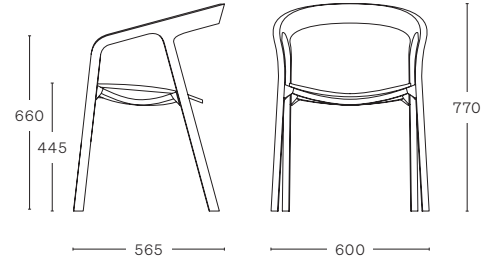

SHE SAID LOWIDE

- Ash frame

Stackable x2 

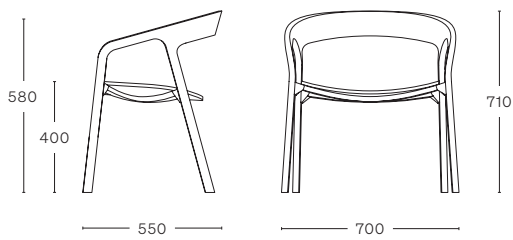

SHE SAID COUNTER STOOL

- Ash frame
- Ash frame with non removable upholstery:
- Rohi Topia

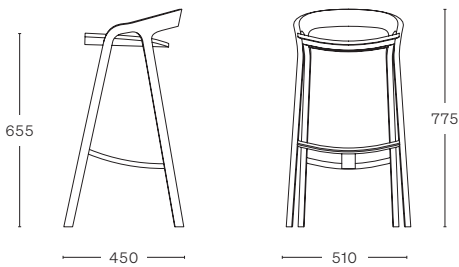

SHE SAID BAR STOOL

- Ash frame
- Ash frame with non removable upholstery:
- Rohi Topia

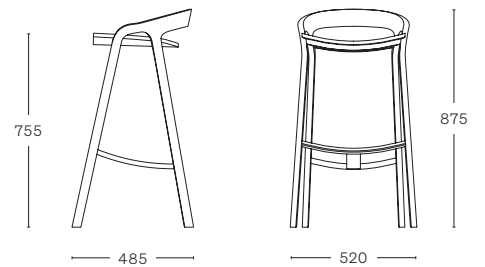

MATERIALS

FRAME

Ash



Natural

Black
RAL 9005

White
RAL 9003

Neon Blue
RAL 5013

UPHOLSTERY

Rohi Topia

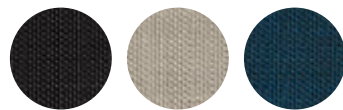

Anthrazit

Chrom

Azur



REF. #0271
Architecture: FLIP Studio Photography: Yunpu Cai



REF. #0301
Architecture: DOMANI Photography: Vincent Wu



REF. #0285
Architecture: Leeton Pointon Photography: Lisa Cohen

RONAN AND ERWAN BOUROULLEC

Ronan (born in 1971) and Erwan Bouroullec (born in 1976) are brothers and designers based in Paris. They have been working together for more than twenty years bonded by diligence and challenged by their distinct personalities. Their studio is based in Paris and their team numbers around ten people.

In 1997, they were spotted by Cappellini, giving them their first industrial design projects. They began working with the Galerie kreo in 2000 and had their first solo show there in 2001. Issey Miyake then hired them to design the boutique to house his new collection A-Poc. They met then Rolf Fehlbaum, President of Vitra, and worked on a new office system entitled Joyn. Since then, they have gone on to work with Artek, Flos, Hay, Kettal, Kvadrat, Ligne Roset, Magis, Mutina, Nanimarquina, Samsung and Vitra, etc.

Their work has covered many field ranging from the design of small objects as jewellery to spatial arrangements and urban designs, from craftsmanship to industrial scale, from drawings to videos and photography. The designers also maintain an experimental activity with Galerie kreo, which is also essential to the development of their work.

STUDIO NITZAN COHEN

Prof. Nitzan Cohen (born in 1973), is a multidisciplinary designer and Dean of the Faculty of Design and Art at the Free University of Bozen-Bolzano.

After completing his studies at the Design Academy Eindhoven, he worked with Konstantin Grcic and later established his own design practice (Studio Nitzan Cohen) collaborating with a wide range of partners, from large international corporations to artisanal workshops, cultural institutes and Museums. Combining design work with design research and didactic, Cohen held the position of Chair for Industrial and System Design at HBK Saarbrücken and was an adjunct professor at the Master for Space & Communication at the HEAD, Geneva.

Currently, he is a professor for product design and the Dean of the Faculty of Design and Art at the Free University of Bozen-Bolzano, where he founded the 'Design Friction Lab'; A multidisciplinary research and design studio at the intersection of science and industry, aiming to merge reality with innovation. The lab focuses on finding sustainable solutions for industrial and societal shifts, with projects ranging from crafted electronics, DIY culture, distributed manufacturing, open-source production, nano-electronics, biodegradable sensors, design driven materials, design for circularity and sustainable production technologies.

Cohen's work was exhibited in museums and galleries worldwide, and his work is part of the most renowned international design collections.

MARIALAURA IRVINE

Marialaura Rossiello Irvine (born in 1972) has been the creative force behind Studio Irvine for over a decade. A graduate of Architecture from Naples under the mentorship of Riccardo Dalisi, Marialaura is guided by an intrinsic respect for the narrative foundations of architecture. She began her career with a passion for traditional design before advancing to Milan to study Strategic Design at Politecnico di Milano. With marketing, communication, and strategy as focal points, she gained valuable experience collaborating with top Italian design firms, viewing products as part of a company's overall strategy. Later, she began blending her expertise with the British design approach, working alongside her late husband, James Irvine. Her design process defies attachment to any single style or typology; it is distinguished by a meticulous methodology fueled by comprehensive research and profound historical understanding that informs each stage of the design journey. Marialaura's philosophy is akin to a radical whisper, advocating the transformative potential of materiality.

Marialaura's portfolio includes collaborations with esteemed clients including Arper, Muji, Thonet, M+, FormaCemento, Olivari, MATTEOBRIANI, among others. Her studio, based in the center of Milan, specializes in product design, art direction, and architecture. The approach is recognizable not only in the final product or space but in the entire process that, starting from the material, involves all the stages of transformation: from production to communication and product strategy. The mission is to simplify to improve the overall design and production. Her research is linked to mono-materiality, always in search of a synthesis that, following an industrial approach, reduces material waste.

LAMBL / HOMBURGER

Studio Lambl Homburger was the joint design practice of Birgitta Homburger and Florian Lambl from 2006-2018. Since then, the founders have pursued their own projects and continue to shape the industry.

Birgitta Homburger is a creative director, designer, and strategist. With a focus on cultural context and strategic thinking she has built an impressive portfolio of work that spans the international stage, including collaborations with brands such as Mattiazzi, Wästberg, Volkswagen, and Laufen Bathroom. Her contributions to the development of Creative Direction and product design have been recognized through her guest professorships at Kunsthochschule Kassel and several institutions like Universität der Künste in Berlin and the Akademie der Bildenden Künste in Stuttgart. In 2023, her dedication to her craft led her to become the Creative Director and partner of Analog, an innovative glass brand based in Berlin.

Florian Lambl took up his professional experience and founded the brand TYP. As a creative director, he leads TYP in publishing furniture, objects, and editions that showcase his unique design sensibilities.

Lambl Homburger partnered with a variety of clients, from global brands to cultural institutions, to help them create authentic and impactful communication strategies. Their expertise in design and branding enabled them to guide Mattiazzi, to a leading furniture brand and its success.

SAM HECHT & KIM COLIN

London-based studio Industrial Facility was co-founded in 2002 by designers Sam Hecht (born in 1969) and Kim Colin (born in 1961). Their approach reflects both a thoughtful consideration of form and a unique understanding of contemporary life, creating beauty out of utility in the products, furniture and exhibitions they design. Hecht, from London, trained as an industrial designer, while Colin, from Los Angeles, trained as an architect; together they have helped clients to produce projects that display an understanding of cultural relevance and commercial success.

Hecht and Colin's desire is to work for industry in a way that improves the things we live with. Not setting out to produce something different but rather something better, they aim to design things that will last, be effective and give satisfaction often beyond what is called for by the product and the client. Industrial Facility is considered as one of the most progressive studios in product, furniture and exhibition design. With a roster of pioneering clients, including Muji, Herman Miller, Emeco, TAKT, Epson and Wästberg, they are regarded for both their philosophical and pragmatic approach.

Their work is included in permanent collections worldwide including Victoria & Albert Museum, MoMA, SFMoMA, Cooper Hewitt, The Art Institute of Chicago, Centre Pompidou, and The Design Museum, London.

KONSTANTIN GRČIĆ

Konstantin Grčić (born in 1965) was trained as a cabinet maker at The John Makepeace School for Craftsmen in Wood before studying Design at the Royal College of Art in London. Since setting up his own practice in 1991 he has developed furniture, products and lighting for leading design companies. Today, Konstantin Grčić Design is based in Berlin and is active in several fields ranging from industrial design projects, design editions, exhibition design and collaborations in architecture and fashion.

Among his producers are Artek, ClassiCon, Flos, Flötotto, Kettal, Laufen, Magis, Mattiazzi, Muji, Mutina, Nespresso, Plank, Serafino Zani and Vitra. From the fashion and lifestyle sector, Audi, Hugo Boss, Issey Miyake, Prada, Rado and smart/Daimler are some of his clients.

Grčić has worked with various institutional clients such as the Venice Architecture Biennial, the Musée des Arts Décoratifs (Paris), the Istituto Svizzero (Rome), the Fonds national d'art contemporain (FNAC), the Serpentine Gallery (London), the St. Etienne Design Biennial, the Vitra Design Museum (Weil am Rhein) and the MUDAM (Luxembourg).

Many of his products have won international design awards, such as the Compasso d'Oro and the German Design Award in Gold.

The world's most important design museums (including MoMA, New York/Centre Pompidou, Paris/Die Neue Sammlung, Munich) have included his designs in their permanent collections.

In 2009, Grčić has been appointed as Honorary Royal Designer for Industry by the Royal Society for the Encouragement of Arts, Manufactures and Commerce (RSA / UK). Since 2020, Grčić holds a professorship at the Hamburg University of Fine Arts (Hochschule für Bildende Künste) and has been appointed member of the Academy of Arts (Akademie der Künste), Berlin in 2021.

JASPER MORRISON

Known for his 'Super Normal' approach to design, Jasper Morrison looks to find the exceptional in the world of the ordinary. He is a firm believer that design should have an almost invisible presence in the end product and that an atmosphere of naturalness in things is more important than a designer's signature.

Born in London in 1959, Jasper studied design at Kingston Polytechnic, the Royal College of Art and Berlin's HdK. In 1986 he opened his Office for Design in London, from where he continues to design furniture, lighting, tableware and everyday products.

STUDIO Ć

Studio Ć is a Berlin-based design studio founded by Lisa Ertel (*1990) and Anne-Sophie Oberkrome (*1990). Both product designers graduated from the University of Arts and Design in Karlsruhe. Their practice ranges from self-initiated works to multidisciplinary collective projects and industrial design commissioned by international companies.

Guided by a fascination for the diverse skills of materials and phenomena observed in everyday life, the duo creates works that tell uncommon stories about the spatial and social context in which their projects move. Anne-Sophie and Lisa are co-founders of the collective FAN. Since 2022, they teach design at HFBK Hamburg.

FOSTER + PARTNERS

Foster + Partners is a global studio for architecture, urbanism and design, rooted in sustainability, which was founded fifty years ago in 1967 by Norman Foster.

Since then, he and the team around him have established an international practice with a worldwide reputation for thoughtful and pioneering design, working as a single studio that is both ethnically and culturally diverse. The studio integrates the skills of architecture with several other disciplines in a collegiate working environment that is similar to a compact university. These diverse skills make us capable of tackling a wide range of projects, particularly those of considerable complexity and scale.

The practice has never drawn a distinction between architecture and industrial design. The point of contact, the thing that you touch, is as important as the broader vision. The industrial design team established in 1980, has developed a wide range of products from door handles to wind turbines; from a fountain pen to the cabin of an executive jet; from a tap to the fit-out of an ocean yacht.

Mike Holland joined Foster + Partners in April 1995. As Head of Industrial Design he leads a team of designers to develop commercial mass manufactured products, lighting, furniture, building products and transportation for clients across the globe. He also works closely with the architectural studios designing bespoke solutions for a diverse range of projects around the world. He designed bespoke furniture and interiors for the Maggie's Centre in Manchester, The National Bank of Kuwait, Apple Park in Cupertino and Bloomberg in London.

LEON RANSMEIER

Leon Ransmeier is the founder and director of Ransmeier Inc., a New York-based design office. A graduate from the Rhode Island School of Design, his work has been published internationally and is included in the permanent collections at the San Francisco Museum of Modern Art and The Corning Museum of Glass.

Clients include 2016/Arita, HAY, Herman Miller, and Maharam. Ransmeier's designs have been exhibited at Cooper Hewitt Smithsonian Design Museum (New York), Friedman Benda Gallery (New York), Swiss Institute (New York), and at SFMOMA (California). His writings on design, art, and architecture have been published in Apartamento, Disegno, and PIN-UP.

JULIE RICHOSZ

Swiss-French designer Julie Richoz set up her eponymous design studio in Paris in 2015, through which she enjoys exploring with curiosity and sensibility the development of her own language through objects. From unique pieces to industrial scale, she sees a continuity rather than a difference between the two ways of production. In both cases, she is fascinated by the savoir-faire and the passion and precision in handling materials.

Her practice ranges from objects, furniture, and lighting to textiles, for companies such as Alessi, Louis Poulsen, Hay, Mattiazzi, La Manufacture de Cogolin, Galerie kroo, among others. After graduating from ECAL University of Art and Design Lausanne (2012), she worked for Pierre Charpin as a project assistant (2013-2015). She was a designer-in-residence at CIRVA Research Center on Art and Glass, France (2013), at Sèvres - Cité de la Céramique, France (2013), and at Casa Wabi, Mexico (2017).

She has been awarded the Grand Prix at Design Parade (2012), Swiss Design Awards (2015/2019), Bourse Leenaards (2016) and the Grand Prix de la Création de la ville de Paris (2023). Since 2017, Richoz has taught industrial design at ECAL University of Art and Design Lausanne, Switzerland.

CREATIVE DIRECTION

Konstantin Grcic with
Florian Böhm, Annahita Kamali
(Studio AKFB)

CATALOGUE DESIGN

Studio AKFB

PHOTOGRAPHY

HIL Architects (p. 22-23)

Joe Fletcher (p. 28-29)

Einar Aslaksen (p. 30; 60-61; 93; 122; 128-129; 146-147; 152-153)

Mikael Olsson (p. 34-35; 44-45; 74-75; 140-141)

Maxime Delvaux (p. 38-39; 66-67; 68-69; 110; 138)

Fabian Frinzel (p. 46-47; 56-57; 84-85; 91; 98-99; 120-121)

Miro Zagnoli (p. 48-49; 54-55)

Ståle Eriksen (p. 52-53; 86-87)

Alberto Strada (p. 80; 106-107)

Ralph Feiner (p. 104-105)

Gerhardt Kellermann (p. 112-113; 124-125; 130; 132-133; 136; 144-145; 146)

PHOTOGRAPHY PRODUCTS

Studio AKFB

COPY EDITING

Rosie Pickles

TRANSLATION

Wendy Wheatley

PRINTING

Poligrafiche San Marco

MATTIAZZI SRL

Via Sottorive, 19 /2

33048 S. Giovanni al Natisone (UD) Italy

T + 39 0432 75 74 74 · F + 39 0432 75 65 72

info@mattiazzi.eu · www.mattiazzi.eu

© 2024 Mattiazzi Srl. All rights reserved. No part of this publication may be reproduced, stored in a retrieval system or transmitted in any form or by any means, electronic, mechanical, photocopying, recording or otherwise, without the permission of Mattiazzi Srl. Mattiazzi reserves the right to introduce any changes to its own models without prior notice.



MATTIAZZI
ITALY